

# PLUS

N-20 シリーズ  
**設置・組立説明書**

---

日本語

N-20 Series Copyboard  
**Assembly and Setup Manual**

---

English

# Copyboard Assembly and Setup Manual

---

This is the installation and assembly manual for the N-20 series Copyboard.  
(The copyboard are referred to as "the set" or "the main unit" in this manual.)

## TABLE OF CONTENTS

1. Please Read in the Interest of Safety .....	E-2
2. Packaging List .....	E-3
3. Mounting the pen tray .....	E-4
4. Assembly of the stand .....	E-5
5. Wall Mounting .....	E-8
6. Connecting the Cables With the Main Unit (Connections Diagram) .....	E-14
7. Test Print .....	E-15

### **To the Customer**

---

Special skills are required to install the set. Never try to assemble the set yourself.

### **To the Dealer or Installation Tradesman**

---

In the interest of the safety of the customer, please perform installation work paying due attention to the strength of the installation location to ensure that it can bear the load of the main unit, printer, and installation parts.

# 1. PLEASE READ IN THE INTEREST OF SAFETY



## Warning

- If you are not a qualified assembly serviceperson, do not perform installation procedures.
- Please be sure to perform the installation and assembly based on this manual. Incorrect installation or assembly will be the cause of injury.
- Please have 2 or more persons lift the main unit when installing or removing it.  
Also, be sure to lock the stand's casters before installing or removing. If not, the stand could slip unexpectedly, resulting in accidents.
- To prevent dropping the strength of the installation location and the anchoring method must fully bear over a long period the load of the main unit, printer, and installation parts. The installation should also be performed to fully withstand an earthquake. Incorrect installation can result in the main unit falling and causing injury.
- Please use M5 or equivalent screws for the wall mounting portion. Use of screws other than M5 or equivalent can result in the main unit falling and causing injury.
- Please mount to a post in the wall or a sturdy wall stud. When the mounting positions of the main unit are not reached, please use optional wall support fittings.
- Please use hardware like anchor nuts and anchor bolts for mounting on a concrete wall.
- Be sure to install the stabilizers supplied with the stand at each of the 4 locations (to prevent toppling).
- The AC adapter box is for storing the AC power adapters of the main unit and printer. The AC power adapters and the power cords heat up. Read the "Important Safety Information" included with the main unit carefully and store the AC power adapters properly.



## CAUTION

- When mounting the printer on the main unit, attach the Velcro to prevent the printer from slipping out due to vibrations.  
Remove the printer when moving the main unit. If not, the printer could fall, resulting in damage or injury.

\* The Velcro is meant to prevent slipping, not to fasten the printer in place.

\* Velcro is a registered trademark of Velcro Industries.

## Note

- *Diagrams of printers that appear in this manual are representative illustrations. The illustration will differ from the actual printer. Check the owner's manual of your printer for information about the names of the connectors and their locations and use.*

## 2. PACKAGING LIST

The contents of the package differ according to the product you have purchased.

Please open the carton and check the parts.

In the rare event that something is missing, please contact your store of purchase.

Package name	Name	Assembly parts
Main unit package	Main unit: 1 unit (standard type or wide type)	Cable clip: Mounted on main unit
	Pen tray: 1	Mount screws (M4 x 20): Temporarily fastened on main unit standard type : 3, wide type : 4
	Wall mounting brackets Top wall brackets : 2 Bottom wall brackets : 2	Main unit lower section mount screws (M4 x 12): 2
	Wall mount printer table: 1 set (*1)	Printer table: 1 Side brackets: 1 left, 1 right AC power adapter box: 1 M4x8 : 4 M4 x 20: 2 (mounted on side brackets) Velcro: 2 sets
	AC power adapter: 1 (with power cord)	
	Dedicated markers: 4 (One each of black, red, blue, and green)	
	Dedicated eraser:1 (with 2 spare sponges)	
	USB cable: 1	
	User's manual: 1	
	Assembly and Setup Manual (this manual) : 1	
	Important Safety Information : 1	
Stand package	T-shape legs (with casters) : 2	Screw caps: 2 Locking knobs : 2 Cable cover: Mounted on stand
	Horizontal bars:1	Mount screws (M5 x 20 mm): 2 (temporarily fastened on side bar) Mount screws (M5 x 45 mm): 2 Sleeves: 2 Plain washer:2
	Stabilizers:4	Hexagonal socket screws (M5 x 8mm):8
	Printer table/AC power adapter box: 1 set (mounted on side bar)	
	Velcro: 2 sets	
	Hexagonal wrench (width across flats: 3 mm): 1	

\*1: The wall mount printer table is sold separately.

# 3. MOUNTING THE PEN TRAY

## Mount the pen tray on the main unit.

- ① Peel off the three pieces (four for the wide type) of temporary fixing tape from the bottom of the main unit.
- ② Insert the heads of the screws in the pen tray's screw holes and slide downwards as such to slip the pen tray into place.
- ③ Tighten the screws.

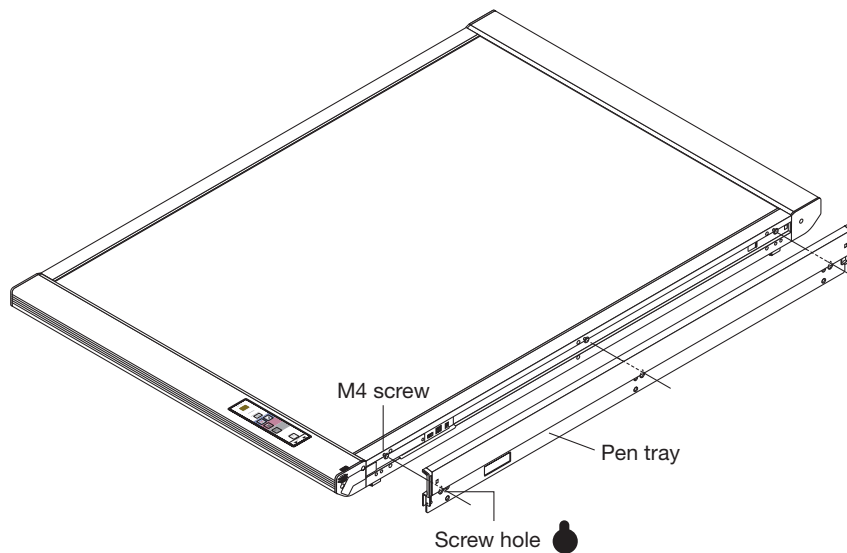
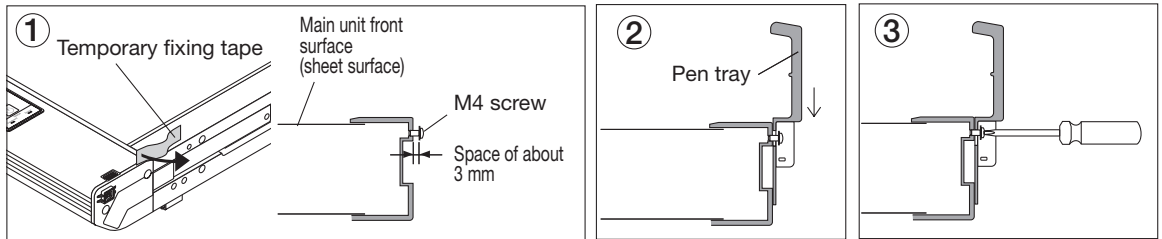

The method of installation differs according to the installation type.  
When installed on the stand: 4. Assembly of the Stand (next page)  
When installed on a wall: 5. Wall Mounting (page E-8)

# 4. ASSEMBLY OF THE STAND

## ⚠ CAUTION

- Lock the casters of the T-shaped feet (left and right). If not, the stand could slip, causing the stand or main unit to fall and resulting in injury or damage.

### 1. Mount the T-shaped feet to the side bar.

The shorter side of the T-shaped foot is the back of the stand. The diagrams show the procedure from the back side. Set the T-shaped foot with the cable cover on the right side (the printer table side).

- ① Remove the temporary fixing tape from the ends of the side bar.

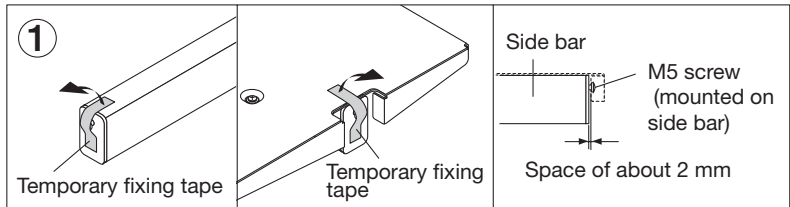

- ② Insert the side bar's screw head into the T-shaped foot's screw hole (on the top), slide downwards, then use the hexagonal wrench to partially fasten.
- ③ Insert the M5 x 45 screw and Plain washer into the sleeve, then use the hexagonal wrench to partially fasten it to the side bar.
  - Check that the sleeve is not sticking out.
  - Once mounting of the left and right T-shaped feet is completed, tighten the four screws, adjusting so there is no looseness.
- ④ Fasten the screw caps to the screw heads of the left and right T-shaped feet.
  - A. With the screw caps set slightly at an angle, place the hooks into the screw holes in the T-shaped feet and slide downwards.
  - B: Press the stoppers of the screw caps into the hollows in the M5 screw heads.

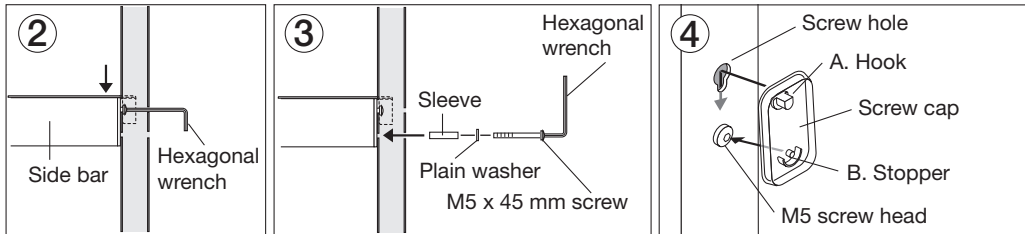

\* The diagram used for explanation here is see-through.

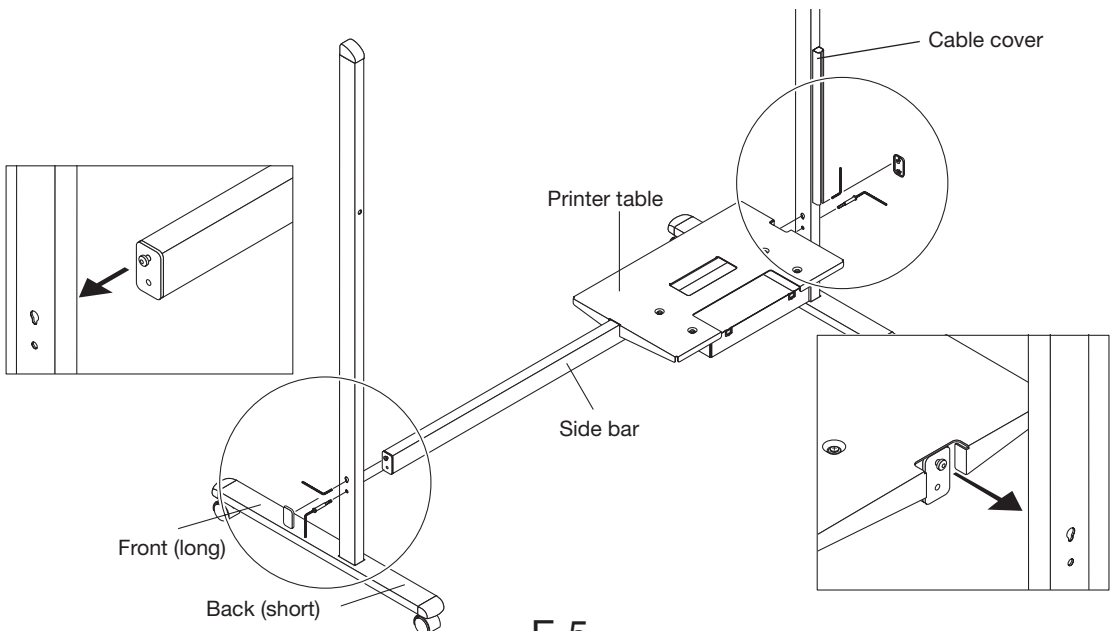

## 4. Assembly of the Stand

### 2. Attach the stabilizers to the front and back of the T-shaped feet.

#### CAUTION

- To prevent toppling, be sure to install the stabilizers at each of the 4 locations. The toppling of this machine could cause bodily injury or damage the machine.

#### ① Alignment of the screw holes of the T-shape feet with those of the stabilizers.

Slide the stabilizers on the T-shaped feet to align with the holes.

#### CAUTION

- Do not lift the stand to work on it. This may lead to toppling or bodily injury.

#### ② Secure the stabilizers on the T-shape feet by hexagonal screws using hexagonal wrench.

Attach the 4 stabilizers on the feet.

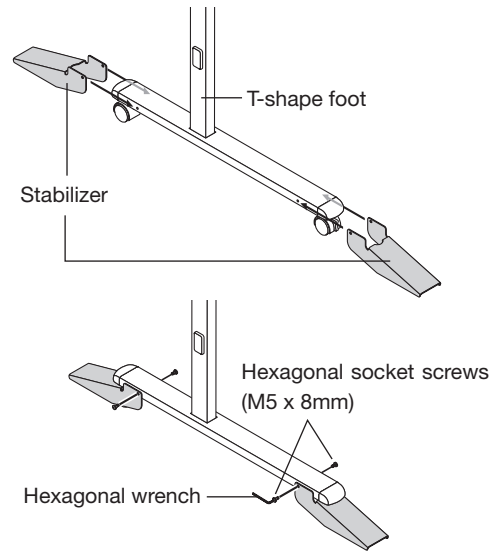

### 3. Mount the main unit on the stand.

The shorter side of the T-shaped foot is the back of the stand. The diagrams show the procedure from the back side.

#### ① Place the stand's hooks in the mounting holes in the main unit's support pieces and insert securely in the hook grooves.

Holes are located in three positions. The mounted height can be adjusted in three steps of 100 mm (1747, 1847 or 1947 mm (maximum height)) according to which holes are used.

#### ② Fasten the main unit with the locking knobs (left and right).

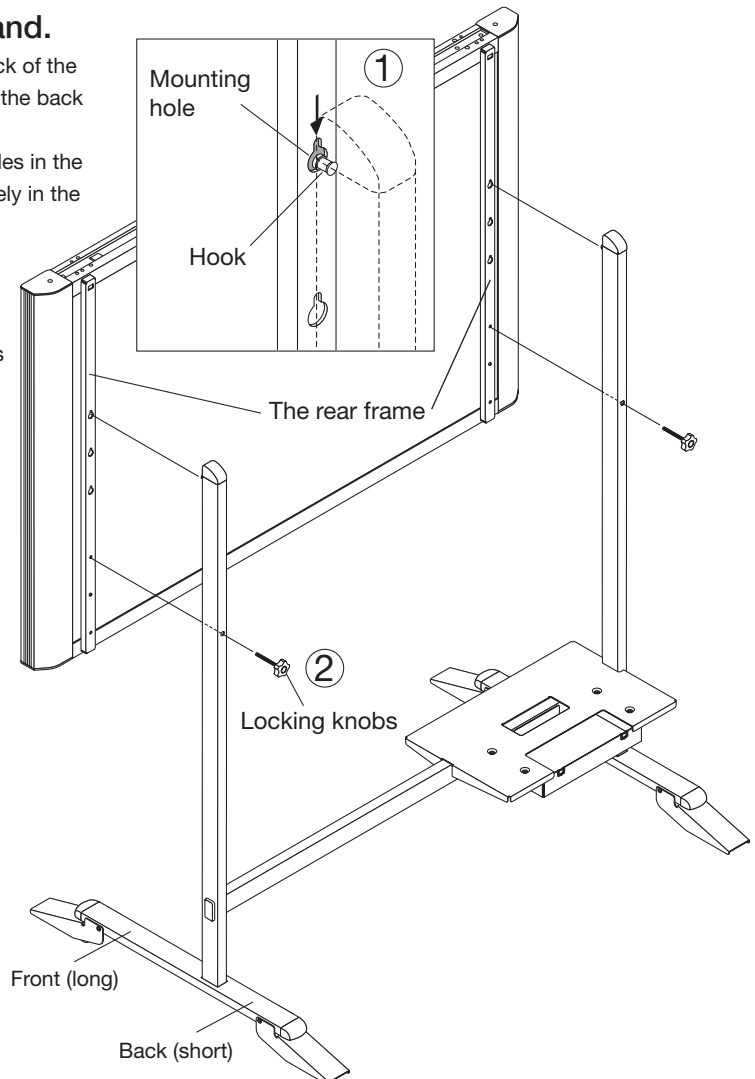

#### CAUTION

- To prevent accidental injury due to the main unit dropping or tipping over, the main unit should be held by at least two persons when mounting it on the stand.
- Check that the stand's hooks are securely inserted into the main unit's mounting holes. If not, the main unit could drop, resulting in injury and damaging the equipment.
- Make sure the locking knobs are tightened when moving. If not, the side bar's mounts could be bent or otherwise damaged.

## 4. Assembly of the Stand

### 4. Store the AC power adapters and cables in the AC power adapter box.

Connect the main unit and printer before storing the adapters and cables. (See page E-14.)

#### CAUTION

- Check that the AC power plug is not connected to a wall power outlet. If it is, be sure to unplug it.

The shorter side of the T-shaped foot is the back of the stand. The diagrams show the procedure from the back side.

- ① Put the AC power adapters of the main unit and printer in the AC power adapter box.

#### WARNING

- The AC power adapters and the power cords generate heat. Be sure to wire them in such a way that they keep apart. Do not bundle the cables together. Doing so could cause them to heat up, leading to fire.

- ② Fasten the cables with the cable clip, then insert them in the cable cover.
- ③ Put the cables into the AC adapter box's cable hole. (The cables enter when pushed in.)
- ④ Peel the backing sheet of the Velcro and attach the Velcro to the bottom of the printer and the printer table. Fasten the Velcro on the printer table in a position opposite the position on which the Velcro is attached on the printer. Also, do not attach the Velcro to a sunken part of the printer, or it will not touch the Velcro on the printer table.

#### CAUTION

- The Velcro is attached to prevent slipping. It is not strong enough to prevent falling. Remove the printer when moving the stand. If not, the printer could be damaged or fall on your feet, etc., causing injury.

- ⑤ Place the printer on the printer table.
  - Place any extra cable length in the AC power adapter box so that no cable is hanging out.

This completes mounting of the main unit on the stand. Make a test print.

See page E-15.

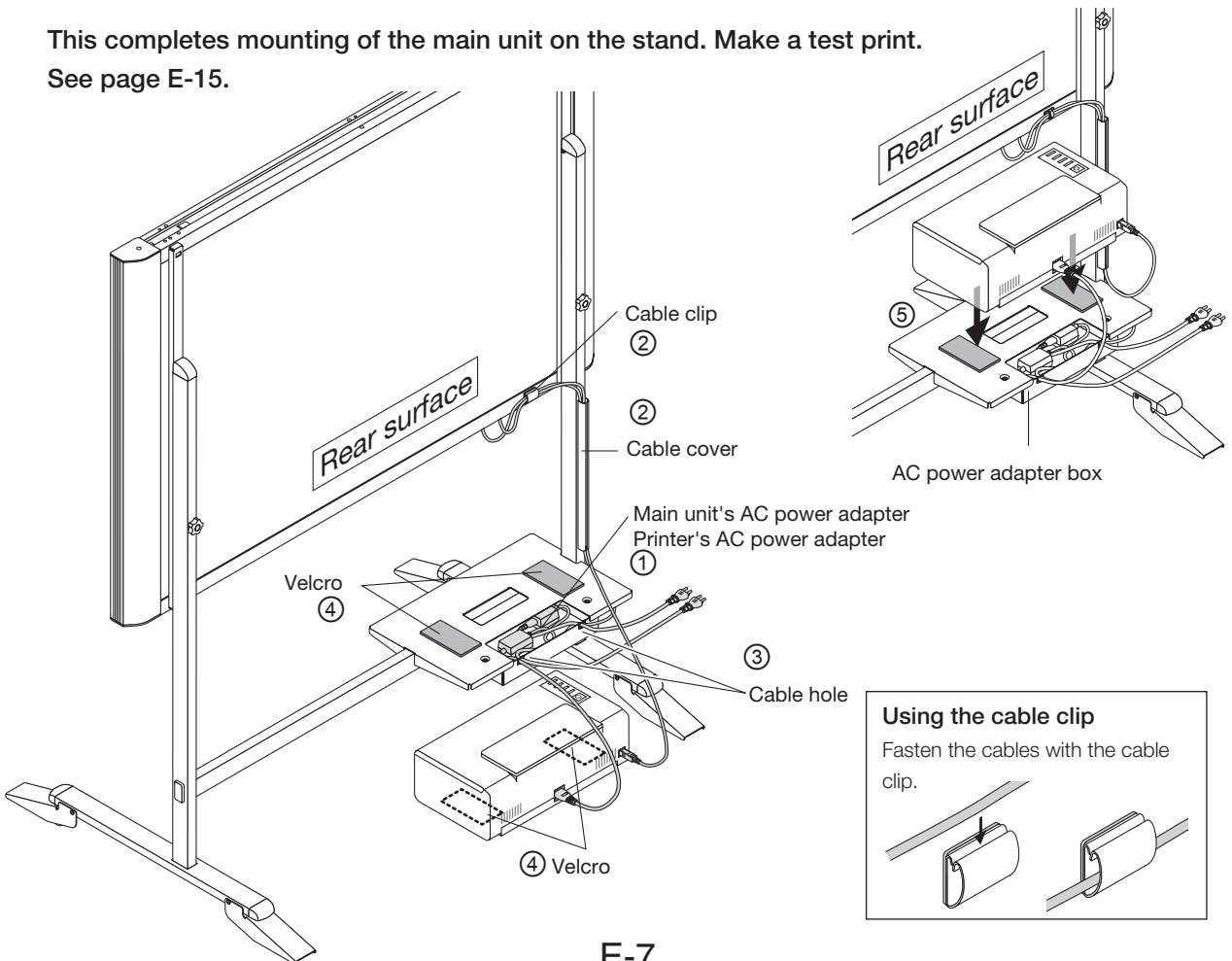



# 5. WALL MOUNTING

Mount the main unit to the wall. Attach the pen tray to the main unit before mounting. (See page E-4.)

## 1. Preparing the place of mounting

Insert a gimlet or other pointed object accurately through the center of the screw holes in the Wall Bracket Mounting Dimensional Drawing below to mark the wall surface.

### ● For plywood and similar wall structures

Make sure that there are columns and/or studs that match up with the mounting dimensions. When there is no column in the desired installation location, place a side board between the nearby columns.

### ● For concrete walls

Place commercially available anchor bolts and anchor nuts for M5 screws in the mounting positions.

#### Note

- When the building does not have posts, please use the stand.

## Wall Bracket Mounting Dimensional Drawing

The dimensions for the bracket mounting positions are the same as shown below.

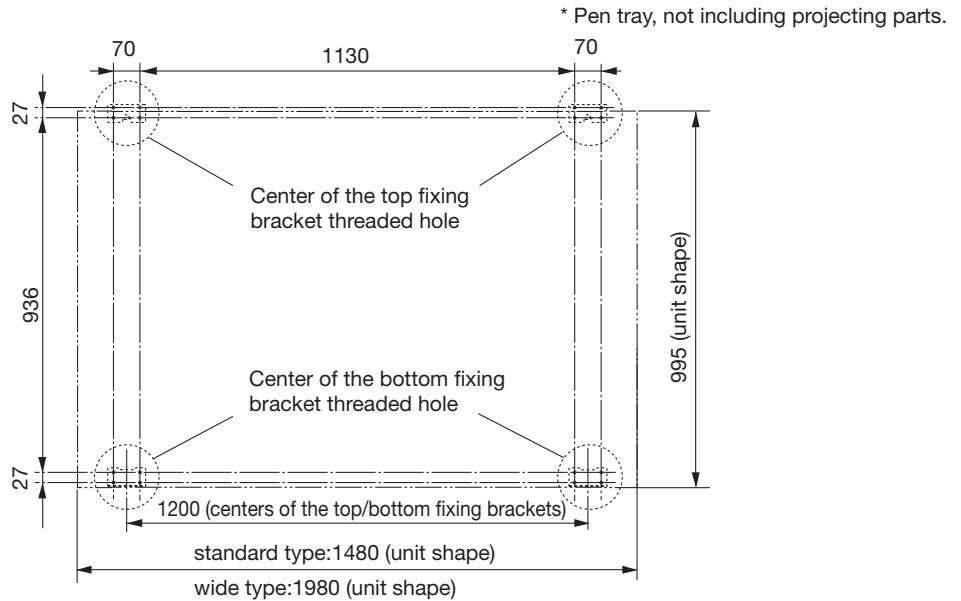

### (Ex.) For plywood and similar wall structures

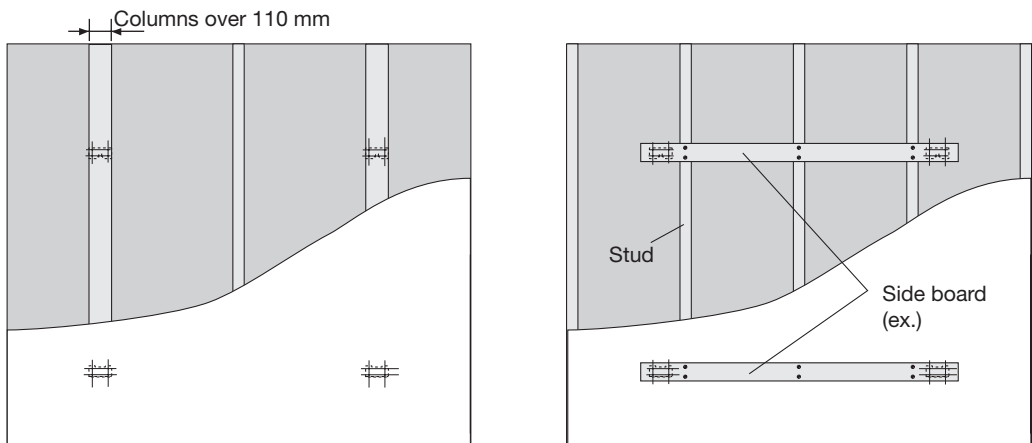

## 5. Wall Mounting

### Reference: Installation Method for Various Wall Materials

Please perform an installation that suits the wall material.

Please install the main unit to posts or studs when the wall surface is of insufficient strength.

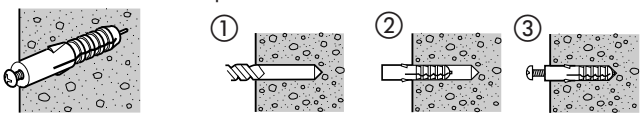
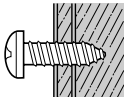
Installation Wall Material	Installation Method
<b>Wooden Walls</b>	<p><b>Wood screws</b></p> <p>① Make a suitable hole with an auger and ② attach the Copyboard with wood screws.</p> 
<b>Concrete Walls</b>	<p><b>Anchors</b></p> <p>① Make a base hole in the wall with a drill. ② Insert the anchor. ③ Fasten the main unit with screws. Please use a drill of the hole diameter specified for the anchor.</p> 
<b>Steel Walls</b>	<p><b>Phillips head tapping screws (Pan head)</b></p> <p>Check that the steel wall is reinforced and use a drill a hole of suitable diameter, then attach the main unit with tapping screws.</p> 

## 2. Fixing the wall brackets to the wall surface

Use screws to fix the wall brackets in the marked positions.

Keeping the structure and material of the wall in mind, use M5 screws to fix wall hangers in place.

The fixing process varies according to the wall mounting method. (See above.)

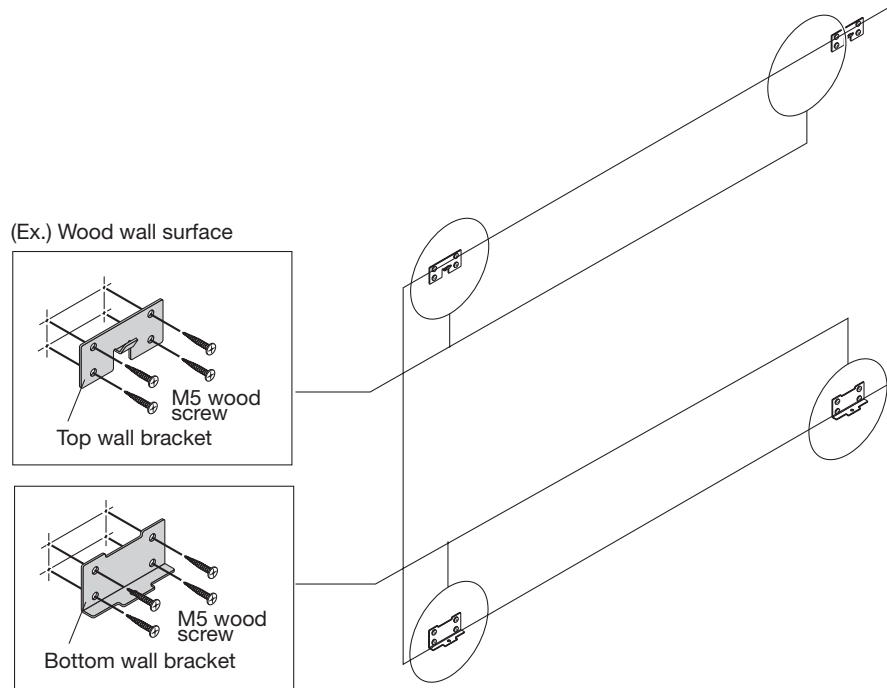

## 5. Wall Mounting

### 3. Placing the unit in the top wall brackets (L/R).

① Put the sockets located on the top of the support pieces on the back of the unit on the top wall bracket hooks, making sure that the sockets are securely in place. ② Then, gently lower the unit and place it on the bottom fixing brackets.

#### CAUTION

- Insert the unit in the top wall brackets with at least 2 people. If the unit comes out of place, it may fall and cause injury.
- After mounting the unit in the top wall brackets, hold the top of the unit and pull it forward to make sure that it is securely in place. If the unit falls, it may cause injury.

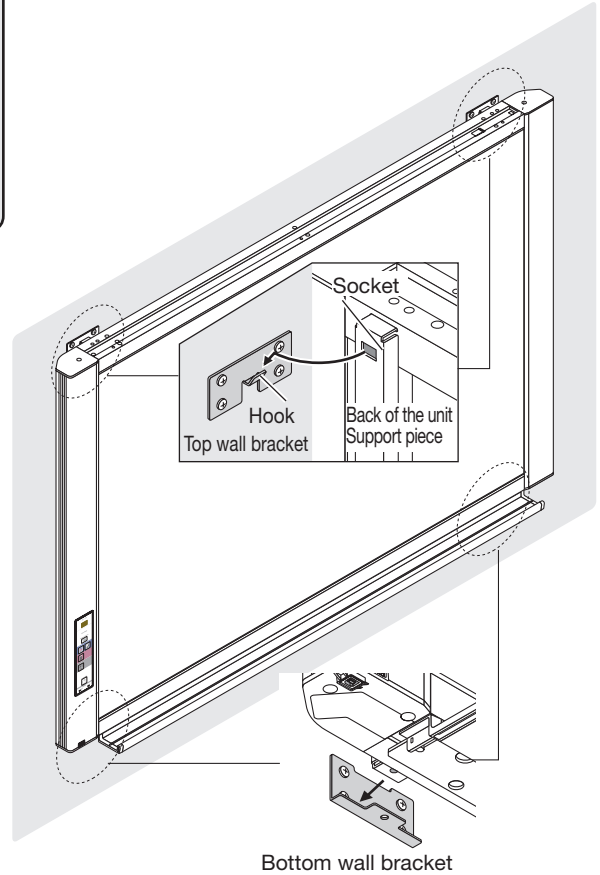
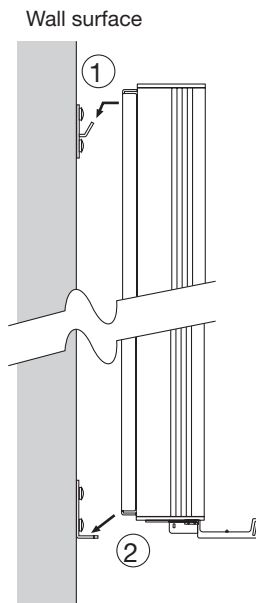

### 4. Fixing the bottoms (L/R) of the unit support pieces to the bottom wall bracket

Fasten the bottom edge of the main unit support pieces using the M4 x 12 screws.

#### CAUTION

When mounting the unit in the bottom wall brackets, do not lift the unit up. Doing so may cause the unit to come out of the top wall brackets. If the unit falls, it may cause injury.

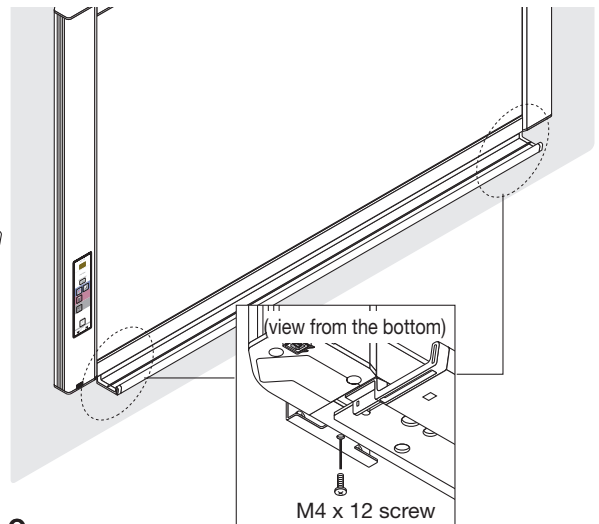
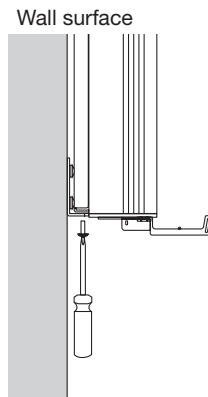

### 5. Assembling the printer table

Fasten the brackets on the sides of the printer table using M4 x 8 screws (three each).

- There is one bracket for the left side, one for the right. Place the flange on the inner side.

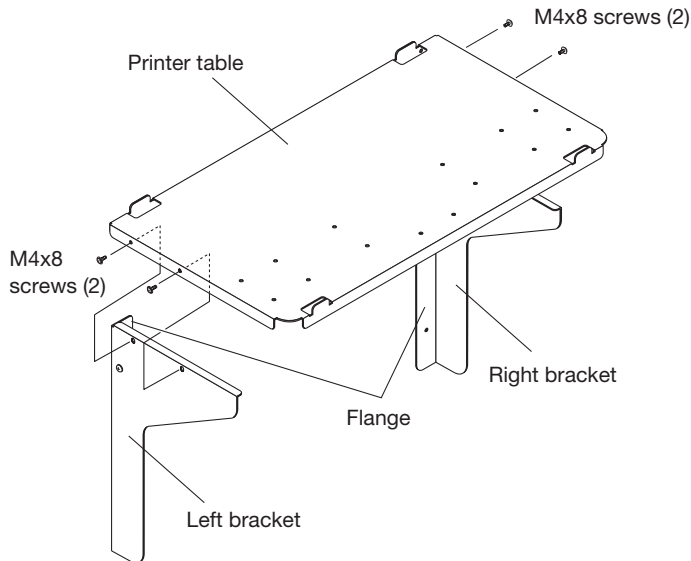

### 6. Mounting the printer table on the wall surface

#### (1) Preparing the place of mounting



- Install the printer table so that the cable for connection with the main unit is within reach.
- Use a printer fitting within the maximum printer outer dimensions of 502 (width) x 275 (depth) (including power cord and other connection cords, etc.). Use a printer weighing no more than 5 kg.

Place the wall printer table at the position in which it is to be mounted, then insert a gimlet or other pointed object accurately through the center of the screw holes to mark the wall surface.

- When the wall structure consists of plywood, etc.  
For panel walls, plaster board walls, etc., make sure there are columns or studs at the mounting dimension positions.  
If there are no columns at the desired installation position, mount a side board between nearby columns.
- For concrete walls  
Place commercially available anchor bolts and anchor nuts for M5 screws in the mounting positions.

#### Wall Mounting Dimensional Diagram

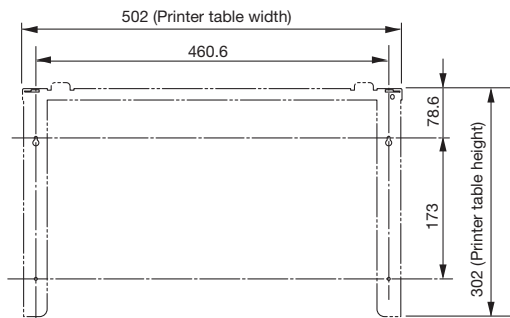

## 5. Wall Mounting

### (2) Fasten the printer table to the wall surface.

Use screws, etc., to fasten the printer table to the marked positions.

Use the appropriate screws for the wall structure and material to fasten the printer.

(The method of fastening differs according to the material of the wall surface. See page E-9.)

- ① Mount M5 screws to the two upper screw positions, about 2 mm apart.
- ② Put the printer table's screw holes over the screw heads in ①, slide downwards, then fasten the screws.
- ③ Fasten the printer table with M5 screws in the two lower screw positions.

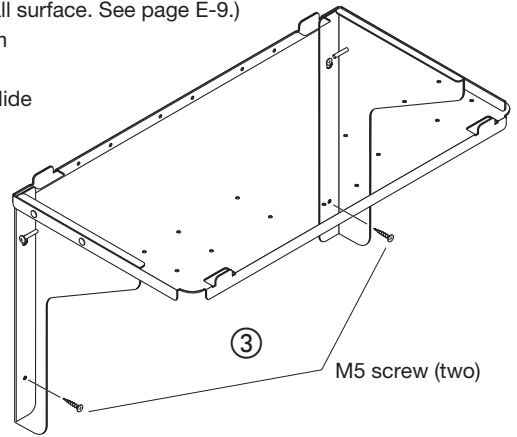
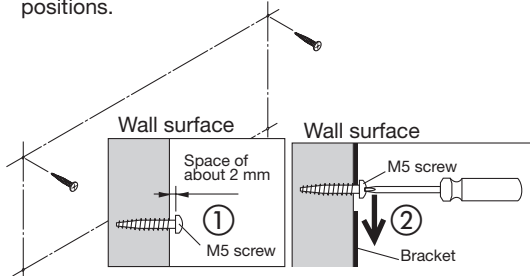

\* The diagram used for explanation here is see-through.

## 7. Store the AC power adapters and cables in the AC power adapter box.

### ⚠ CAUTION

- Check that the AC power plug is not connected to a wall power outlet. If it is, be sure to unplug it.

- ① Peel the backing sheet of the Velcro and attach the Velcro to the bottom of the printer and the printer table. Fasten the Velcro on the printer table in a position opposite the position on which the Velcro is attached on the printer. Also, do not attach the Velcro to a sunken part of the printer, or it will not touch the Velcro on the printer table.

### ⚠ CAUTION

- The Velcro is attached to prevent slipping. It is not strong enough to prevent falling. Remove the printer when moving the stand. If not, the printer could be damaged or fall on your feet, etc., causing injury.

- ② Connect the main unit's printer terminal and the printer using the USB cable.
- ③ There is a cable hole on the wall side of the printer table. Pass the DC cable of the main unit's AC power adapter and the printer's AC power cable through the printer table's cable hole before connecting.  
For instructions on connecting the main unit and printer, see page E-14.
- ④ Place the printer on the printer table.

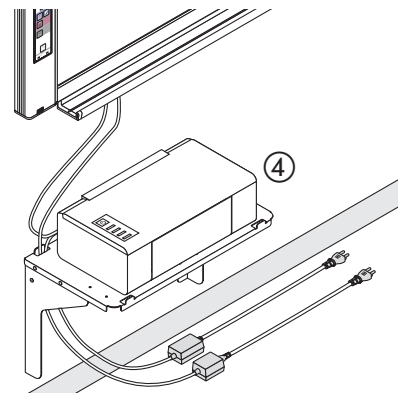
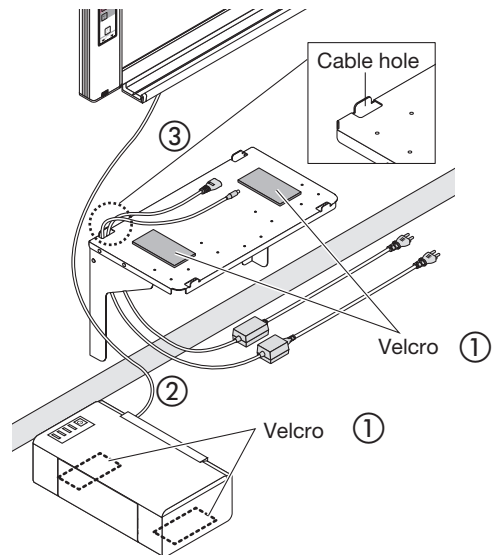

## 5. Wall Mounting

- ⑤ Put the main unit's AC power adapter and the printer's AC power adapter in the AC power adapter box. Place any extra cable length in the AC power adapter box so that no cable is hanging out.

### WARNING

- The AC power adapters and the power cords generate heat. Be sure to wire them in such a way that they keep apart. Do not bundle the cables together. Doing so could cause them to heat up, leading to fire.

- ⑥ Put the cables in the notches (top and bottom) on the left side of the AC power adapter box and attach the AC power adapter box to the printer table.

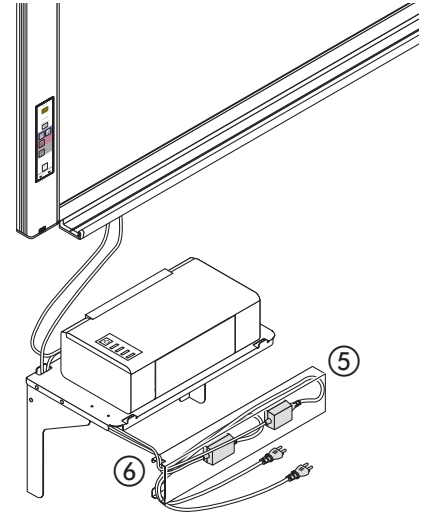

\* The diagram used for explanation here is see-through.

- ⑦ Catch the upper flange of the AC power adapter box on the left and right bracket screws (M4 x 20) to suspend the AC power adapter box.

**This completes wall mounting.**  
**Make a test print. See page E-15.**

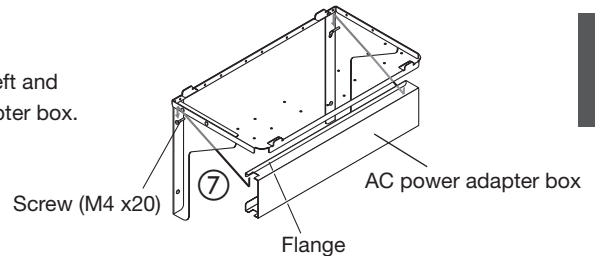

For explanation purposes, the printer and connection wires are omitted from this diagram.

## 6. CONNECTING THE CABLES WITH THE MAIN UNIT (CONNECTIONS DIAGRAM)

Connect as shown on the diagram below. Do not connect the AC power adapters' AC power plugs to the wall power outlet yet.

Once connections are completed, store the AC power adapters and cables in the AC power adapter box. The way this is done differs depending on whether the main unit is installed on the stand or the wall.

When installed on the stand: See page E-5.

When installed on a wall: See page E-8.

### [Copyboard and Printer Connections Diagram]

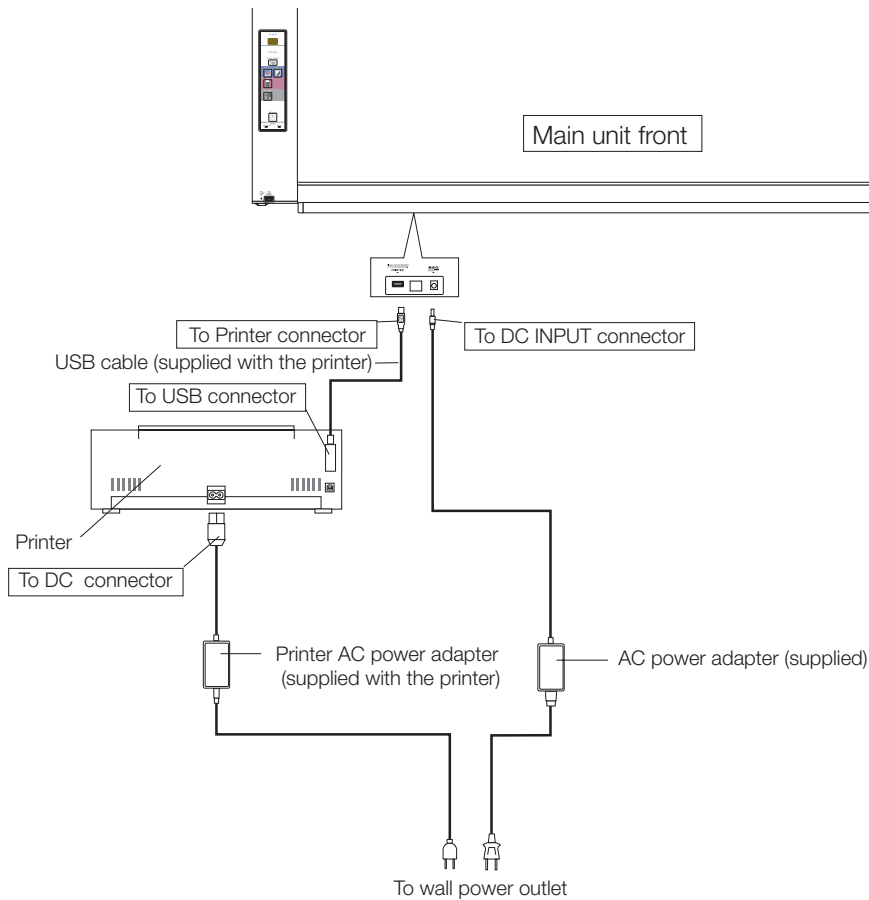



\* Appearance of printer is for illustration purposes.

#### Note

The AC power adapters of accessories and printers that have been verified to be operation many differ from the ones shown on the connections diagram (they may be of the built-in or mounted-on type).

## 7. TEST PRINT

Remove the printer cartridge installation seals and the protective sheet used for shipping before using the printer for the first time. Please see your printer manual for details.

- (1) Plug the AC power plugs of the main unit and printer into a wall power outlet.
- (2) Press the ON/Standby  button of the main unit and switch on the power.
- (3) Switch on the printer power.
- (4) Open the top cover and open the paper tray.
- (5) Set A4 or letter size paper.
- (6) Write or draw a diagram on the sheet surface.
- (7) Press the color print button  for a color print, the black and white print button  for a black and white print.

### Notice

*Depending on the printer, the display indicators might flash after turning on the power and continue to flash until printing preparation is completed. If this occurs, refer to the printer manual and start the printing operation with the main unit after checking that printing preparation has been completed.*

**This completes test printing.**



# PLUS Corporation

## プラス株式会社

本製品に関するお問い合わせ

TEL ☎0120-944-086

FAX ☎0120-331-859

ISO 14001 認証取得