

iDECT

USER GUIDE

iDECT C5i System

**Digital Cordless Telephone with
50 Name and Number Phonebook
and Answering Machine**



THIS EQUIPMENT IS NOT DESIGNED FOR MAKING EMERGENCY TELEPHONE CALLS WHEN THE POWER FAILS. ALTERNATIVE ARRANGEMENTS SHOULD BE MADE FOR ACCESS TO DIAL EMERGENCY SERVICES.

Important note-

This telephone is not designed to make calls in the event of a power failure. So you should make alternative arrangements for access to Emergency Services.

We recommend that a standard telephone that operates without mains power be connected to your telephone line so that you can make calls during a power failure.

If you need help ...

The Helpline is available from 9:00 am to 5:00 pm, Monday to Friday on

0845 345 9677

Calls are charged at Local Call rate.

Charging your batteries for the first time

Before you start to use your telephone, make sure that the batteries are fully charged for 15 hours.

Unpacking your phone

In the box you will find:

- one **cordless handset** (two handsets for Twin system, three handsets for Triple system and four handsets for Quad system)
- one **base unit**
- two **rechargeable batteries** for each handset
- one **battery compartment cover** for each handset
- one **telephone line cable** for the base unit
- one **mains power cable with adaptor** for the base unit
- **charging pods**, each with an attached mains power cable and **adaptor**, for multihandset system

*** Keep your sales receipt as it is your guarantee.*

Where to find it

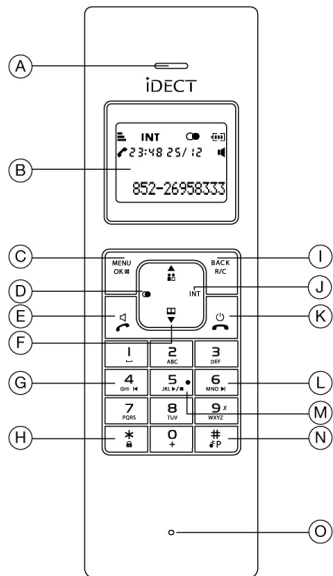

F UP/DOWN navigation key

- Press up or down to scroll through the menu or list options
- From standby, press up to view Call list (CID)
- From standby, press down to access Phonebook
- Press up or down to adjust volume during a call

G SKIP BACK key

- Go back to previous message or replay current message in answering machine mode.

H */KEYLOCK key

- From standby, press and hold to activate or deactivate the key lock

I BACK/R/C key

- Return to previous menu or the main menu
- During a call, press to send a Recall (Flash) signal
- Clear a digit or character

J INT key

- Make an internal call
- Make a 3 way conference call between 2 internal callers and 1 external caller

K HANG-UP key

- End a call
- From standby, press and hold to power the handset off. Press to turn back on.
- Return to standby

L SKIP key

- Skip to next message in answering machine mode

M PLAY/STOP key

- From standby, press and hold to start message playback
- Play/Stop message playback in answering machine mode

N # /PAUSE/RINGER OFF key

- From standby, press and hold to turn ringer Off / On
- Press and hold to insert a pause (P) when dialling or saving a number
- Switch between upper and lower case when entering text

O Microphone

A Earpiece

B LCD display

C MENU/OK/MUTE key

- Access to main menu
- Select a menu entry
- Mute the microphone during a call

D REDIAL key

- View Redial list

E TALK/SPEAKER key

- Make a call
- Answer a call
- Switch to speakerphone mode on / off during a call

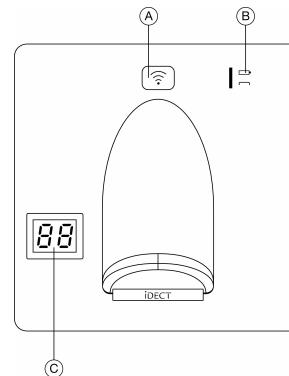

A FIND key

- Page handsets
- Register handset

B Charge/In use indicator

- On steady when a handset is on charge on the base or when the line is in use.
- Flashes when there is an incoming call or if there are new answering machine or call list messages.







C Message counter



- Shows the number of messages and status of the answering machine
- XX** : Steady On - The number of old messages recorded.
- XX** : Flashing - The number of new messages recorded.
- : The answering machine is turned off.
- Ro** : The answering machine is in Answer Only mode
- Rn** : The answering machine is recording.
- BB / XX** : Alternating - The memory is full and XX new messages.

Selecting a menu option

The phone uses a menu system on the handset to access all its features. You may access the following items through the main menu:

Phonebook, Set Date/Time, Personal Set, Advanced Set, Answ. Machine.

-  To access the main menu, press **MENU/OK** .
-  Press **UP**  or **DOWN**  to select a menu option.
-  Press **MENU/OK**  to confirm the option and enter its sub-menu.

** Press **BACK/R/C**  to return to the previous menu or press **HANG-UP**  to return to standby mode.

What's on the display?



What do the icons mean?



Flashes when the handset is trying to establish a link to the base unit.
On steady when linked to the base.



On when there is a new call in the calls list. (The display also shows XX New Call, where XX is the number of new calls.)

Flashes when you have a new Voice Mail message. (This is a Caller Display service and is not usually available from UK network providers.)



Flashes when there is an incoming intercom call.
On steady when setting up or connected on an intercom call.



On when the phonebook is accessed.



On when the handset ringer volume is off (in Silence mode).



On when the redial list is accessed.



On when the keypad is locked.



Battery level indicator. When it shows **nearly empty** place the handset on charge. The icon scrolls when the batteries are being charged.



On steady when you are on an external call.
Flashes when there is an incoming external call (even when the ringer volume is off).



On when the answering machine function is turned on.
Flashes when there is a new message on the answering machine. (The display also shows X New Msg, where X indicates the number of new messages.)



On when the speakerphone is turned on.

Contents

| | | | |
|---|-----------|---|-----------|
| Read First Before Use | 2 | Using multi-handset capabilities | 17 |
| Installation and Set-up | 4 | Making an intercom call | 17 |
| Install rechargeable batteries into the handset | 4 | Transfer an external call | 17 |
| Connecting the mains power supply | 4 | Set up a three-way conference call | 18 |
| Basic Telephone Operations | 5 | Personalising your phone | 19 |
| Switching the handset on/off | 5 | Handset tones | 19 |
| To lock/unlock the keypad | 5 | Handset Name | 20 |
| Set time and date | 5 | Auto answer | 21 |
| Switch speakerphone on/off | 6 | Auto hang-up | 22 |
| Making a Call | 6 | Language | 22 |
| Answering a call | 6 | Base ringer volume / melody | 23 |
| Ending a call | 7 | Advanced phone settings | 24 |
| Adjust earpiece volume | 7 | Recall time (Flash) | 24 |
| Paging the handset | 7 | Registration | 24 |
| Mute | 7 | Unregister a handset | 25 |
| Phonebook | 8 | Modify the PIN code | 25 |
| Reviewing the phonebook | 8 | Reset | 26 |
| Adding a phonebook entry | 8 | Using the answering machine | 27 |
| Dialling from the phonebook | 9 | Switch the answering machine on/off | 27 |
| Editing a phonebook entry | 10 | Playback recorded messages | 28 |
| Deleting a phonebook entry | 10 | Memo recording | 29 |
| Deleting all phonebook entries | 11 | Set the answer mode and outgoing messages (OGM) | 30 |
| Using the redial list | 12 | Set ring delay | 31 |
| Redial the last entry | 12 | Remote access operation | 32 |
| Dialling from the redial list | 12 | Call screening | 34 |
| Save an entry in the phonebook | 12 | Troubleshooting | 37 |
| Delete a redial entry | 13 | Cleaning and care | 40 |
| Delete all redial list entries | 13 | Declaration of conformity | 40 |
| Caller Display | 14 | Guarantee and service | 42 |
| Reviewing the call list | 14 | Technical details | 43 |
| Dialling from the call list | 14 | | |
| Save an entry in the phonebook | 15 | | |
| Delete a call list entry | 15 | | |
| Delete all call list entries | 16 | | |

Read First Before Use

Choosing a location for the base unit and charging pod

The base unit and charging pod(s) should be placed on a level surface and in a location where:

- the mains adapter plug can easily reach the 230-V AC mains supply socket - never try to lengthen the mains power cable
- the telephone cable of the base unit can reach the telephone wall socket or extension socket (the charging pod does not have a telephone line connection)
- it is not close to another telephone - this can cause radio interference
- it is not close to a sink, bath or shower, or anywhere else where it might get wet
- it is not close to other electrical equipment - fridge, washing machine, microwave oven, fluorescent lights, television, etc.
- it is away from hot, humid conditions and strong sunlight

Radio signals between the handset and base unit

To use your handset and base unit, you must be able to establish and maintain a radio link between them. Be aware that any large metal objects, like a refrigerator, a mirror, filing cabinet, etc, between the handset and the base unit may block the radio signal. Other solid structures, like walls, may also reduce the signal strength.

Connections and conditions for use

You can connect your iDECT C5i to a direct exchange line (DEL) — a line connected to a local exchange, with its own phone number; to an extension socket connected to a DEL; or to an extension on an approved compatible PBX. Do not connect the iDECT C5i as an extension to a payphone.

The ringer equivalence numbers (RENs) of all instruments (phones, fax machines, etc.) connected to an exchange line must not add up to more than 4 — otherwise, one or more of them may not ring and/or answer calls correctly. The iDECT C5i has a REN of 1, and most other telephones have a REN of 1 unless marked otherwise.

Interference

If the sound quality gets worse as you move around when on a call, this is probably caused by interference between the handset and the base unit. Perhaps you are too near to another phone or other electrical equipment. Move to a different position to clear the interference. Otherwise, it might cause a short break or your call may be disconnected.

Mains power connection

IMPORTANT - The base unit and charging pod must be used with the power adapters supplied with the unit. Using any other adapters will result in non-compliance with EN60950, and will invalidate any approval given to this equipment.

Battery safety - CAUTION

ONLY use the rechargeable batteries supplied with the handset. **DO NOT** use non-rechargeable batteries - they may explode and cause damage to your telephone.

CAUTION

RISK OF EXPLOSION IF BATTERY IS REPLACED
BY AN INCORRECT TYPE.
DISPOSE OF USED BATTERIES ACCORDING
TO THE INSTRUCTIONS.

If you have a Broadband line

If you connect your telephone to a line with broadband connection, you will need to insert a microfilter (not included) between the telephone and telephone line, otherwise you may get interference between the telephone and the broadband, which could cause problems.

In a home with broadband, every telephone must have a microfilter connected, not just the one at the telephone point that your modem is connected to. If you need more broadband microfilters, contact your broadband supplier.

Installation and Set-up

Install rechargeable batteries into the handset

- 1** Install the two Ni-MH, AAA size, rechargeable batteries into the handset in accordance with the polarity markings in the battery compartment.
- 2** Close the battery compartment cover by sliding it into place and pressing firmly to make sure that it is secure.

Connecting the mains power supply

- 1** Plug the base power cord into the power jack at the bottom of the base unit and connect the other end to a 100-240Vac 50-60Hz electrical outlet.
- 2** Plug the telephone line cord into the phone jack at the bottom of the base unit and connect the other end to a telephone wall socket.
- 3** Connect the charger adaptor to a 100-240Vac 50-60Hz electrical outlet.

Notes:

- Before you use the cordless handset for the first time, it is important to charge the batteries fully.
- Leave the handset on the charging cradle for 15 hours.
- The battery charge icon will scroll when you are charging the battery.
- If the icon is not showing the correct battery charge level, first verify that the handset is correctly placed in the charging cradle. If it is placed correctly, try to remove and re-install the batteries. Please note that it is normal for the mains adaptor to become warm - this does not indicate a fault.

CAUTION: Use only the power adaptors that are supplied with this unit. Using other power adaptors may damage the unit.

Basic Telephone Operations

Switching the handset on/off

To switch on



If the display is blank, press **HANG-UP**

To switch off



In standby mode, press and hold **HANG-UP**

** You can switch the handset off to save on battery power.

Note: When the handset is OFF, it cannot be used to make calls, including emergency calls. It will not ring when there is an incoming call. To answer or make a call, you will need to switch it back on. It may take some time for the handset to re-establish a radio link with the base unit.

To lock/unlock the keypad

To lock



Press and hold

→ The display shows **Keys Locked** and the

To unlock











Press and hold





or simply replace the handset on the charging cradle.

Set time and date

If you have subscribed to Caller Display service, the time and date will be set automatically when you receive a call.

-  Press **MENU/OK**  to enter the main menu.
-  Press **UP**  or **DOWN**  to select **Set Date/Time**.
-  Press **MENU/OK**  to select.
→ The display shows **00:00 01/01**, with the first number flashing.
-  Enter the time (in 24-hour mode), the date and the month, then press **MENU/OK**  to confirm.
→ A confirmation beep is played.



Switch speakerphone on/off

-  1 During a call, press **TALK/SPEAKER** .
→  icon appears on the display.
-  2 To switch back to earpiece mode, press **TALK/SPEAKER**  again.





Note: If you are using the speakerphone, stay close to handset so that the other party can hear you clearly.

Making a Call

Direct dial

-  1 Press **TALK/SPEAKER** .
→ You will hear a dial tone.
-  2 Dial the desired number.



Pre-dial

-  1 Dial the desired number (maximum 24 digits).
 If you make a mistake, press **BACK/R/C**  to clear the digits from the display.
-  2 Press **TALK/SPEAKER** .

Note: You may need to insert a pause in the number if your phone is connected to a PBX (for example, after you dial 9 for an outside line, or while waiting for a computer access tone). Each pause entered will delay the dialling sequence by about 2 seconds.

Press and hold **#/PAUSE/RINGER**  to insert a P in the dialling sequence.

Answering a call

-  1 When the phone rings, lift up the handset and press **TALK/SPEAKER** .
→ The call timer is displayed after 20 seconds, showing the duration of the call.

Note: If Auto answer is set to On (see page 21), you can simply lift the handset off the charging cradle to answer the call without having to press **TALK/SPEAKER** .

Ending a call





Press **HANG-UP** .

→ The total call duration is displayed for 5 seconds.

Note: Auto hang-up mode is set to On by default. You can simply replace the handset on the charging cradle to end the call without having to press **HANG-UP**  and the handset returns to standby mode. To turn off this mode, see page 22.





Adjust earpiece volume



You may adjust the earpiece volume by pressing **UP**  or **DOWN**  during a call.





There are three volume levels to choose from. When the maximum or minimum volume level is reached, the phone beeps twice.

Paging the handset

-  Press **FIND**  on the base unit.
→ All handsets registered to the base will ring for up to 30 seconds.
-  To stop paging, press **FIND**  again or press any key on any of the handsets.

Mute











You can mute the microphone during a call and talk to someone else without your caller hearing you.

-  During a call, press **MENU/OK/MUTE**  to mute the microphone.
→ The display shows **Mute On**.
-  Press **MENU/OK/MUTE**  again to unmute the microphone.

Phonebook

You can store up to 50 entries in the phonebook for quick dialling. Names can be up to 10 characters long and numbers up to 20 digits. You can also set different melodies for your phonebook entries, but these will only play if you subscribe to Caller Display and the incoming number matches the stored number.









Reviewing the phonebook

-  Press **PHONEBOOK** .
→ All entries are shown in alphabetical order.
** If the phonebook is empty, the display shows **List Empty**.
-  Press **UP**  or **DOWN**  to scroll through the list or use the keypad to enter the first letter of the name to go to the desired entry.
-  Press **MENU/OK**  to view the number and, if necessary, press # to see more digits and the selected ring melody for that number.
-  Press **UP**  or **DOWN**  to view the previous or next entry or press **HANG-UP**  to return to standby mode.

Note: Alternatively, you can review your phonebook entries via the main menu.

Press **MENU/OK**  to enter the main menu. Select **Phonebook > List Entry** to view the phonebook entries.

Adding a phonebook entry

-  Press **MENU/OK**  to enter the main menu.
-  Press **MENU/OK**  again to select **Phonebook**.
-  Press **MENU/OK**  to select **New Entry**.
→ The display shows **Enter Name**.
-  Use the keypad to enter a name (up to 10 characters). If you make a mistake, press **BACK/R/C**  to clear the characters from the display.



Notes:

For example, to enter the name BILL,

- Press twice to enter the letter B.

- Press three times to enter the letter I.

- Press three times to enter the letter L.

- Press three times again to enter the second letter L.

**You need to wait 2 seconds before entering a second letter from the same key.

To insert a space, press .

To switch between upper and lower case characters, press

#/PAUSE/RINGER .

5



Press **MENU/OK** to save the name.

→ The display shows **Enter Number**.

6



Use the keypad to enter a number (up to 20 digits). If you make a mistake,

press **BACK/R/C** to clear the digits from the display.

7



Press **MENU/OK** to save the number.

→ The display shows **Select Melody**
Melody 5

8



Press **UP** or **DOWN** to select a melody (**Melody 1 to Melody 10**) from the list. The melody is played as you make your selection.

9



Press **MENU/OK** to save the entry or press **HANG-UP** to cancel.

Dialling from the phonebook

1



Press **PHONEBOOK** .

→ All the entries are shown in alphabetical order.

** If the phonebook is empty, the display shows **List Empty**.

2



Press **UP** or **DOWN** to scroll though the list or use the keypad to enter the first letter of the name to go to the desired entry.

3

































Press **TALK/SPEAKER** to dial.

4

















To end the call, press **HANG-UP** .

Editing a phonebook entry













-  Press **MENU/OK**  to enter the main menu.
-  Press **MENU/OK**  again to select Phonebook.
-  Press **UP**  or **DOWN**  to select **Edit Entry**.
-  Press **MENU/OK**  to confirm.
-  Press **UP**  or **DOWN**  to select an entry.
-  Press **MENU/OK**  to confirm.
→ The display shows **Enter Name** and the existing name of the entry.
-  Press **BACK/R/C**  to clear the characters from the display and use the keypad to enter a new name.

-  Press **MENU/OK**  to save the name.
→ The display shows **Enter Number** and the existing number of the entry.
-  Press **BACK/R/C**  to clear the digits from the display and use the keypad to enter a new number.

-  Press **MENU/OK**  to save the number.
→ The display shows **Select Melody** and the current melody selected for the entry.
-  Press **UP**  or **DOWN**  to change the melody that you want.
-  Press **MENU/OK**  to save the entry or press **HANG-UP**  to cancel.

Deleting a phonebook entry

-  Press **MENU/OK**  to enter the main menu.
-  Press **MENU/OK**  again to select Phonebook.
-  Press **UP**  or **DOWN**  to select **Delete Entry**.
-  Press **MENU/OK**  to confirm.
→ All the entries are shown in alphabetical order.

- 5  Press **UP**  or **DOWN**  to select an entry.
- 6  Press **MENU/OK**  to confirm deletion or press **HANG-UP**  to cancel.





Deleting all phonebook entries

- 1  Press **MENU/OK**  to enter the main menu.
- 2  Press **MENU/OK**  again to select Phonebook.
- 3  Press **UP**  or **DOWN**  to select Delete All.
- 4  Press **MENU/OK**  to confirm.
→ The display shows Confirm?.
- 5  Press **MENU/OK**  to confirm deletion or press **HANG-UP**  to cancel.









Using the redial list

The redial list stores the last 10 numbers dialled.













Redial the last entry











-  Press **REDIAL** .
→ The display shows **Redial** and the most recent number dialled, with the last number dialled appearing at the top of the list.
** If the redial list is empty, the display shows **List Empty**.
-  Press **TALK/SPEAKER**  to redial the last number.

Dialling from the redial list













-  Press **REDIAL** .
→ The display shows **Redial** and the most recent number dialled.
** If the redial list is empty, the display shows **List Empty**.
-  Press **UP**  or **DOWN**  to select an entry.
-  Press **TALK/SPEAKER**  to dial that entry.
-  To end the call, press **HANG-UP** .

Save an entry in the phonebook













-  Press **REDIAL** .
→ The display shows **Redial** and the most recent number dialled.
-  Press **UP**  or **DOWN**  to select an entry.
-  Press **MENU/OK**  to confirm.
-  Press **MENU/OK**  again to select **Copy to Phbk**.
→ The display shows **Enter Name**.
-  Use the keypad to enter a name (up to 10 characters). If you make a mistake, press **BACK/R/C**  to clear the characters from the display.
-  Press **MENU/OK**  to save the name.
→ The display shows **Enter Number**.

- 7  Use the keypad to edit the number (up to 20 digits), and using **BACK/R/C**  to clear digits from the display, if necessary.
- 8  Press **MENU/OK**  to save the number.
→ The display shows **Select Melody**
Melody 5
- 9  Press **UP**  or **DOWN**  to select a melody (Melody 1 to Melody 10) from the list. The melody is played as you make your selection.
- 10  Press **MENU/OK**  to save the entry or press **HANG-UP**  to cancel.

Delete a redial entry

- 1  Press **REDIAL** .
→ The display shows **Redial** and the most recent number dialled.
- 2  Press **UP**  or **DOWN**  to select an entry.
- 3  Press **MENU/OK**  to confirm.
- 4  Press **UP**  or **DOWN**  to select **Delete**.
- 5  Press **MENU/OK**  to confirm deletion or press **HANG-UP**  to cancel.

Delete all redial list entries

- 1  Press **REDIAL** .
→ The display shows **Redial** and the most recent numbers dialled.
- 2  Press **MENU/OK** .
- 3  Press **UP**  or **DOWN**  to select **Delete All**.
- 4  Press **MENU/OK**  to confirm.
→ The display shows **Delete All?**
- 5  Press **MENU/OK**  to confirm deletion or press **HANG-UP**  to cancel.

Caller Display

To receive Caller Display information on your phone, you must subscribe to Caller Display Service from your service provider.

With Caller Display, you will be able to see your callers' numbers (provided the calls are not withheld) on your handset before answering the calls, and in the call list afterwards.

The call list stores details of the last 20 different, answered or unanswered, incoming calls, including the caller's number as well as the date and time information.





If you've got new Caller Display records, the handset will display **XX New Call.**, where **XX** indicates the number of new missed calls.

If the received number is the same as one in your phonebook, the name from the phonebook will be displayed instead of the number.



If the call is from someone who withheld their number, e.g. ex-directory or by dialling 141, the display will show **ID Withheld**.







If the call is from someone whose number is unavailable, e.g. an international call or from a private exchange, the display will show **Out Of Area**.

Reviewing the call list























-  Press **CID**  .
→ The display shows **Call list** and the most recent incoming call, with a number (1 to 20) to indicate its position in the list, where a higher number is more recent.
** If the call list is empty, the display shows **List Empty**.
-  Press **UP**  or **DOWN**  to view the entries.
Note: Press **#** to see more details of the call, cycling through the Name (if present), the number, and the date/time.

Dialling from the call list





-  Press **CID**  .
→ The display shows **Call list** and the most recent incoming call.
** If the call list is empty, the display shows **List Empty**.

- 2  Press **UP**  or **DOWN**  to select an entry.
- 3  Press **TALK/SPEAKER**  to dial.
- 4  To end the call, press **HANG-UP** .

Save an entry in the phonebook













- 1  Press **CID** .
→ The display shows Call list and the most recent incoming call.
- 2  Press **UP**  or **DOWN**  to select an entry.
- 3  Press **MENU/OK**  to confirm.
- 4  Press **MENU/OK**  again to select Copy to Phbk.
→ The display shows Enter Name.
- 5  Use the keypad to enter a name (up to 10 characters). If you make a mistake, press **BACK/R/C**  to clear the characters from the display.
- 6  Press **MENU/OK**  to save the name.
→ The display shows Enter Number.
- 7  Use the keypad to edit the number, if necessary (up to 20 digits). If you make a mistake, press **BACK/R/C**  to clear the digits from the display.
- 8  Press **MENU/OK**  to save the number.
→ The display shows Select Melody
Melody 5
- 9  Press **UP**  or **DOWN**  to select a melody (Melody 1 to Melody 10) from the list. The melody is played as you make your selection.
- 10  Press **MENU/OK**  to save the entry or press **HANG-UP**  to cancel.

Delete a call list entry

- 1  Press **CID** .
→ The display shows Call list and the most recent incoming call.
- 2  Press **UP**  or **DOWN**  to select an entry.

- 3  Press **MENU/OK**  to confirm.
- 4  Press **UP**  or **DOWN**  to select **Delete**.
- 5  Press **MENU/OK**  to confirm deletion or press **HANG-UP**  to cancel.

Delete all call list entries

- 1  Press **CID** .
→ The display shows **Call list** and the most recent incoming call.
- 2  Press **MENU/OK** .
- 3  Press **UP**  or **DOWN**  to select **Delete All**.
- 4  Press **MENU/OK**  to confirm.
→ The display shows **Delete All?**
- 5  Press **MENU/OK**  to confirm deletion or press **HANG-UP**  to cancel.









Using multi-handset capabilities

If you have an iDect C5i multi-handset system, you already have more than one handset registered to your base unit. You can register additional handsets to the base which can handle a maximum of 5 handsets. The handset number (1 to 5) is shown on the display.

With two or more handsets registered, you can make intercom calls between the handsets, transfer an external call from one handset to another, toggle between an external call and an intercom call, or set up a three-way conference call between one external call and two handsets.







Note: Only one handset can be connected to an external line at a time, except for in conference mode. If you try to make a call while another handset is on the line, you will hear a busy tone.

Making an intercom call

-  Press **INT**.
→  icon and a list of handset numbers appears on the display.
-  Enter the handset number that you want to call.
→ The called handset rings. The ringer melody of an intercom call is different from that of an external call.
-  On the called handset, press **TALK/SPEAKER**  to answer the intercom call.
-  To end the call, press **HANG-UP**  on either handset..

Transfer an external call





You can transfer an external call to another handset that is registered to the base unit.

-  During an external call, press **INT**.
→ The external call is put on hold and a list of handset numbers appears on the display.
-  Enter the handset number that you want to transfer the call to.
-  When the called handset answers, you can announce the call.
-  Press **HANG-UP**  on the calling handset to transfer the call or press **HANG-UP**  on the called handset to cancel the transfer, and return the external call automatically to the calling handset.

Note: If the called handset does not answer within 20 seconds, the call will be returned and you will be connected automatically back to your external call.

Set up a three-way conference call

When you have both an external call and an intercom call in progress, you can set up a three-way conference call.

















- 1**  During an external call, press **INT**.
→ The external call is put on hold and a list of handset numbers appears on the display.
- 2**  Enter the handset number that you want to have the conference call with.
- 3** When the called handset answers, you can announce the call.
- 4**  Press and hold **INT** on the calling handset to start a three-way conference call.
- 5**  To end the call, press **HANG-UP** .

Note: When one party leaves the conference, the other two parties will remain connected.

Personalising your phone

Handset tones



















Set the ringer volume

-  Press **MENU/OK**  to enter the main menu.
-  Press **UP**  or **DOWN**  to select Personal Set.
-  Press **MENU/OK**  to confirm.
-  Press **MENU/OK**  again to select Handset Tones.
-  Press **MENU/OK**  again to select Ring Volume.
-  Press **UP**  or **DOWN**  to select the desired ringer volume level (High, Medium, Low, Silence).
-  Press **MENU/OK**  to save your setting.

Note: If you select Silence,  icon will be displayed.



















Set the ringer melody

You may choose from 10 different ringer melodies.

-  Press **MENU/OK**  to enter the main menu.
-  Press **UP**  or **DOWN**  to select Personal Set.
-  Press **MENU/OK**  to confirm.
-  Press **MENU/OK**  to select Handset Tones.
-  Press **UP**  or **DOWN**  to select Ring Melody.
-  Press **MENU/OK**  to confirm.
-  Press **UP**  or **DOWN**  to select a melody (Melody 1 to Melody 10) from the list. The melody is played as you make your selection.
-  Press **MENU/OK**  to save your setting.

Switch key beeps on/off















You can choose to switch off the beep sound when you press the keys.

-  Press **MENU/OK**  to enter the main menu.
-  Press **UP**  or **DOWN**  to select **Personal Set**.
-  Press **MENU/OK**  to confirm.
-  Press **MENU/OK**  to select **Handset Tones**.
-  Press **UP**  or **DOWN**  to select **Key Beep**.
-  Press **MENU/OK**  to confirm.
-  Press **UP**  or **DOWN**  to select **On** or **Off**.
-  Press **MENU/OK**  to save your setting.

Handset Name

In standby mode the handset displays a handset name (default: **HANDSET**) and the handset number.

You can personalise each handset by setting a different display name for your handsets. Each name can be up to 10 characters long.

-  Press **MENU/OK**  to enter the main menu.
-  Press **UP**  or **DOWN**  to select **Personal Set**.
-  Press **MENU/OK**  to confirm.
-  Press **UP**  or **DOWN**  to select **Handset Name**.
-  Press **MENU/OK**  to confirm.
-  Press **BACK/R/C**  to clear the characters from the display and use the keypad to enter a new name (up to 10 characters).



Notes:

For example, to enter the name BILL,

- Press  twice to enter the letter B.

- Press  three times to enter the letter I.

- Press  three times to enter the letter L.

- Press  three times again to enter the second letter L.

**You need to wait 2 seconds before entering a second letter from the same key.

To insert a space, press .

To switch between upper and lower case characters, press **#/PAUSE/RINGER** .

7



Press **MENU/OK**  to save your setting.

Auto answer

If this mode is set to On, you can simply lift the handset off the charging cradle to answer an incoming call during ringing without having to press **TALK/SPEAKER** . The default setting is Off.

1



Press **MENU/OK**  to enter the main menu.

2



Press **UP**  or **DOWN**  to select **Personal Set**.

3



Press **MENU/OK**  to confirm.

4



Press **UP**  or **DOWN**  to select **Auto Answer**.

5



Press **MENU/OK**  to confirm.

6



Press **UP**  or **DOWN**  to select **On** or **Off**.

















7



Press **MENU/OK**  to save your setting.

















Auto hang-up

If this mode is set to On, you can simply replace the handset on the charging cradle to end the call without having to press **HANG-UP**  and the handset returns to standby mode. The default setting is On.

- 1  Press **MENU/OK**  to enter the main menu.
- 2  Press **UP**  or **DOWN**  to select **Personal Set**.
- 3  Press **MENU/OK**  to confirm.
- 4  Press **UP**  or **DOWN**  to select **Auto Hang-up**.
- 5  Press **MENU/OK**  to confirm.
- 6  Press **UP**  or **DOWN**  to select **On** or **Off**.
- 7  Press **MENU/OK**  to save your setting.



















Language

This defines the language used for ALL the menu instructions on the handset display, and can be changed from English, if required.

- 1  Press **MENU/OK**  to enter the main menu.
- 2  Press **UP**  or **DOWN**  to select **Personal Set**.
- 3  Press **MENU/OK**  to confirm.
- 4  Press **UP**  or **DOWN**  to select **Language**.
- 5  Press **MENU/OK**  to confirm.
- 6  Press **UP**  or **DOWN**  to select the desired language.
- 7  Press **MENU/OK**  to save your setting.























Base ringer volume / melody

Set the base ringer volume

- 1  Press **MENU/OK**  to enter the main menu.
- 2  Press **UP**  or **DOWN**  to select **Personal Set**.
- 3  Press **MENU/OK**  to confirm.
- 4  Press **UP**  or **DOWN**  to select **BaseTone**.
- 5  Press **MENU/OK**  to confirm.
- 6  Press **MENU/OK**  again to select **BS Ring Vol**.
- 7  Press **UP**  or **DOWN**  to select the desired ringer volume level (Ring Vol High, Ring Vol Med, Ring Vol Low, Silence).
- 8  Press **MENU/OK**  to save your setting.

Set the base ringer melody















You may choose from three different base melodies.

- 1  Press **MENU/OK**  to enter the main menu.
- 2  Press **UP**  or **DOWN**  to select **Personal Set**.
- 3  Press **MENU/OK**  to confirm.
- 4  Press **UP**  or **DOWN**  to select **BaseTone**.
- 5  Press **MENU/OK**  to confirm.
- 6  Press **UP**  or **DOWN**  to select **BS Ring Mel**.
- 7  Press **MENU/OK**  to confirm.
- 8  Press **UP**  or **DOWN**  to select a base melody (Melody 1 to Melody 3) from the list. The melody is played as you make your selection.
- 9  Press **MENU/OK**  to save your setting.

Advanced phone settings

Recall time (Flash)

You may need to change the recall (flash) time if your phone is connected to a PBX. Three options are available: Short (85ms), Medium (100ms) and Long (250ms). The default is Medium, which is the standard UK requirement.













-  Press **MENU/OK**  to enter the main menu.
-  Press **UP**  or **DOWN**  to select **Advanced Set**.
-  Press **MENU/OK**  to confirm.
-  Press **MENU/OK**  again to select **Recall Time**.
-  Press **UP**  or **DOWN**  to select **Medium, Short or Long**.
-  Press **MENU/OK**  to save your setting.







Registration

If you have purchased a iDECT C5i multi-handset system, all handsets come pre-registered to the base unit. You do not need to register them again. Handset registration is only necessary when you buy extra handsets or if a handset has become faulty.

You can register additional handsets to have up to five handsets per base unit, with each handset's number (1 to 5) shown on its display. (Note: each handset can only be registered to one base.)

















To register a handset to the base:

-  Press **MENU/OK**  to enter the main menu.
-  Press **UP**  or **DOWN**  to select **Advanced Set**.
-  Press **MENU/OK**  to confirm.
-  Press **UP**  or **DOWN**  to select **Registration**.
-  Press **MENU/OK**  to confirm.
→ The display shows **Enter PIN** _ _ _ _ .

- 6  Use the keypad to enter the 4-digit PIN code (default PIN code is 0000).
- 7  Press **MENU/OK**  to confirm.
→ The display shows **Registering...**
- 8  Press and hold **FIND**  on the base until the base starts beeping.
After a short while you will hear a confirmation tone on the handset.
→ The display shows the handset numbers available for registration.
- 9  Enter the handset number you want, or after 7 seconds it will automatically select the first available one.
→ This number is displayed on the handset during standby mode.
You may need to use it for intercom calls.

Unregister a handset















You may need to do this in order to replace a faulty handset.

- 1  Press **MENU/OK**  to enter the main menu.
- 2  Press **UP**  or **DOWN**  to select **Advanced Set**.
- 3  Press **MENU/OK**  to confirm.
- 4  Press **UP**  or **DOWN**  to select **Unregister**.
- 5  Press **MENU/OK**  to confirm.
→ The display shows **Enter PIN _ _ _ _**.
- 6  Use the keypad to enter the 4-digit PIN code (default PIN code is 0000).
- 7  Press **MENU/OK**  to confirm.
→ The display shows the handset numbers available for de-registration.
- 8  Enter the handset number to unregister.
- 9 You will hear a confirmation tone if the de-registration is successful, and the de-registered handset will show **Unregistered**.
Warning: You can de-register the handset you are using.

Modify the PIN code

You need to enter a 4-digit master PIN code if you wish to change the settings of some functions. The default PIN code is 0000. This function allows you to change the PIN code to your own preferred number.

- 1  Press **MENU/OK**  to enter the main menu.

- 2  Press **UP**  or **DOWN**  to select **Advanced Set**.
- 3  Press **MENU/OK**  to confirm.
- 4  Press **UP**  or **DOWN**  to select **Change PIN**.
- 5  Press **MENU/OK**  to confirm.
→ The display shows **Enter New PIN** ____.
- 6  Use the keypad to enter your new 4-digit PIN code.
- 7  Press **MENU/OK**  to confirm.
→ The display shows **Confirm PIN** ____.
- 8  Press **MENU/OK**  to confirm your setting.
→ The display shows **New PIN Stored**.



















Note: Keep a safe record of your new PIN. You will need to enter this PIN between steps 4 and 5 before you can change your PIN code again.

Reset

You can reset your phone to the original default settings.

Note: All your Phonebook entries, Redial list, Call list and recorded messages/memos in the answering machine will be deleted after a reset.

Follow the steps below to restore your phone to its default factory settings.

- 1  Press **MENU/OK**  to enter the main menu.
- 2  Press **UP**  or **DOWN**  to select **Advanced Set**.
- 3  Press **MENU/OK**  to confirm.
- 4  Press **UP**  or **DOWN**  to select **Reset**.
- 5  Press **MENU/OK**  to confirm.
→ The display shows **Enter PIN** ____.
- 6  Use the keypad to enter the 4-digit PIN code (default PIN code is 0000).
- 7  Press **MENU/OK**  to confirm.
→ The display shows **Confirm Reset?**.
- 8  Press **MENU/OK**  to confirm the reset or press **HANG-UP**  to cancel.

Using the answering machine

















Your phone includes a telephone answering machine that is switched on by default and preset to answer a call automatically after five rings.

It will play a pre-defined outgoing message to prompt the caller to leave a message if they wish to, up to 2 minutes per message. The total recording time available for all messages is about 15 minutes.

You can personalise the settings of the answering machine to suit to your needs.

Switch the answering machine on/off

When the answering machine is On,  icon will appear steadily on the display.





















-  Press **MENU/OK**  to enter the main menu.
-  Press **UP**  or **DOWN**  to select Answ. Machine.
-  Press **MENU/OK**  to confirm.
-  Press **UP**  or **DOWN**  to select Ans. On/Off.
-  Press **MENU/OK**  to confirm.
-  Press **UP**  or **DOWN**  to select On or Off.
-  Press **MENU/OK**  to save your setting.

Note: When the answering machine is turned off, it will still answer calls, but only after about 15 rings and with the Answer Only message, so the caller will not be able to leave a message, but it will allow remote access, if required.





Playback recorded messages

When a new message is received on the answering machine,  icon will flash on the handset display, and the message counter will flash on the base display.

The handset display shows X New Msg. to indicate the number of new messages received.

-  Press **MENU/OK**  to enter the main menu.
-  Press **UP**  or **DOWN**  to select Answ. Machine.
-  Press **MENU/OK**  to confirm.
-  Press **MENU/OK**  again to select Play.
-  The first new message will play through the speakerphone.
Press **UP**  or **DOWN**  to adjust the speaker volume if necessary.
**** If there are no new messages, the first old message will play.**
**** To switch to earpiece mode, press TALK/SPEAKER** .
-  During playback, press **MENU/OK**  to enter the playback menu.
-  Press **UP**  or **DOWN**  to select the playback options:
 - Repeat - Replay the current message
 - Next Message - Skip to the next message
 - Prev. Message - Go back to the previous message
 - Delete - Delete the current message
 - Delete All - Delete all messages
-  Press **BACK/R/C**  to return to the previous menu or press **HANG-UP**  to return to standby mode.

















Note: You can also use the digit keys to start playback and select playback options:

- Press and hold  for 2 seconds to start the playback from standby mode.
- Press  to go back to the previous message.
- Press  to skip to the next message.
- Press  to stop playback.
- Press  to delete the current message.

Memo recording

You can record a memo that can be played back later. This can be useful if you want to leave a message for other users of the phone.

A memo will be played back with other recorded messages from external callers.

-  Press **MENU/OK**  to enter the main menu.
-  Press **UP**  or **DOWN**  to select **Answ. Machine**.
-  Press **MENU/OK**  to confirm.
-  Press **UP**  or **DOWN**  to select **Record Memo**.
-  Press **MENU/OK**  to start recording.
→ The display shows **Recording Memo**.
-  Speak clearly into the handset to record your memo. Press **MENU/OK**  to save and end the recording.
-  Press **BACK/R/C**  to return to the previous menu or press **HANG-UP**  to return to standby mode.

Set the answer mode and outgoing messages (OGM)

There are two answering modes - Answer & Record mode or Answer Only mode.

















The Answer & Record mode is switched on by default so that callers can leave messages when their calls are answered by the answering machine.

You can change the answer mode and / or record your own personal outgoing messages.

If Answer Only mode is set, calls are answered and a message played automatically to the caller, but the caller cannot leave a message.





Your callers are greeted with an OGM when the call is answered by the answering machine.

You can use either the pre-defined OGM or record a personalised OGM for this greeting.

















-  Press **MENU/OK**  to enter the main menu.
-  Press **UP**  or **DOWN**  to select **Answ. Machine**.
-  Press **MENU/OK**  to confirm.
-  Press **UP**  or **DOWN**  to select **Answ. Mode**.
-  Press **MENU/OK**  to confirm.
-  Press **UP**  or **DOWN**  to select **Answ. & Rec. or Answer Only**.
-  Press **MENU/OK**  to confirm.
** Now you have to choose either the pre-defined or personalised outgoing message for the selected answer mode.

EITHER select a pre-defined OGM

There are two pre-defined OGMs - one for the Answer & Record mode and the other for the Answer Only mode.



















-  Press **UP**  or **DOWN**  to select **Predefined**.
-  Press **MENU/OK**  to confirm.
→ The pre-defined message is played, followed by a confirmation beep.

OR select a personalised OGM

- 8  Press **UP**  or **DOWN**  to select Personalised.
- 9  Press **MENU/OK**  to confirm.
- 10  EITHER press **MENU/OK**  again to select Play message if you wish to check the existing message.
 OR press **UP**  or **DOWN**  to select Record mess..
- 11  Press **MENU/OK**  to start recording.
→ The display shows Recording.
- 12  Speak clearly into the handset to record your OGM. Press **MENU/OK**  to save and end the recording.
→ The recorded OGM is played back automatically.
- 13  Press **BACK/R/C**  to return to the previous menu or press **HANG-UP**  to return to standby mode.

Set ring delay

Ring delay sets the number of times your phone will ring before the answering machine answers a call and starts playing the outgoing message.

- 1  Press **MENU/OK**  to enter the main menu.
- 2  Press **UP**  or **DOWN**  to select Answ. Machine.
- 3  Press **MENU/OK**  to confirm.
- 4  Press **UP**  or **DOWN**  to select Settings.
- 5  Press **MENU/OK**  to confirm.
- 6  Press **MENU/OK**  again to select Ring Delay.
- 7  Press **UP**  or **DOWN**  to select the number of rings (Rings 3 to Rings 8) or Toll Saver.
- 8  Press **MENU/OK**  to confirm your setting.

Note: If you select **Toll Saver** mode, the answering machine will answer after 5 rings if there are no new messages, or after 2 rings if there is at least one new message recorded.

Note: If the answering machine is turned off or the memory is full it will answer after 15 rings, with the **Answer Only** message.























Note: If the memory is full, you will have to delete some messages before it will be able to record any more new messages.

Remote access operation



Once the remote access function is activated, you can check the recorded messages or turn the answering machine on or off, even when you are away from home, by calling from another phone.

To use this function, you must be using a tone dialling telephone and you will need to enter your 4-digit PIN code (default PIN code is 0000).

To activate remote access

- 1  Press **MENU/OK**  to enter the main menu.
- 2  Press **UP**  or **DOWN**  to select **Answ. Machine**.
- 3  Press **MENU/OK**  to confirm.
- 4  Press **UP**  or **DOWN**  to select **Settings**.
- 5  Press **MENU/OK**  to confirm.
- 6  Press **UP**  or **DOWN**  to select **Remote access**.
- 7  Press **MENU/OK**  to confirm.
- 8  Press **UP**  or **DOWN**  to select **On** or **Off**.
- 9  Press **MENU/OK**  to confirm your setting.

To check messages remotely

- 1  Using a tone dialling phone, call your home number.
- 2  When you hear the outgoing message, enter the 4-digit PIN code (default PIN code is 0000) within 5 seconds.
→ You will hear a short confirmation beep.













3



Press  to start message playback.

** When messages are not playing, you must press a key within 15 seconds or your call will be disconnected.























Keys for remote operation

| | |
|--|---|
|  | Play messages (New messages will be played. To play all old messages, press  again.) |
|  | Skip to the next message |
|   | Go back to the previous message |
|   | Delete the current message |
|  | Switch the answering machine On (Answer & Record), Announce (Answer Only), Off |
|   | Stop message playback |
|  | Replay the current message |
|  | Pause message playback (restart with 2) |

Call screening

This function allows you to hear the caller on the Handset 1 speakerphone while the message is being recorded. You can then decide if you want to talk to the caller directly.

To stop the recording and take the call, simply press **TALK/SPEAKER** .

-  Press **MENU/OK**  to enter the main menu.
-  Press **UP**  or **DOWN**  to select **Answ. Machine**.
-  Press **MENU/OK**  to confirm.
-  Press **UP**  or **DOWN**  to select **Settings**.
-  Press **MENU/OK**  to confirm.
-  Press **UP**  or **DOWN**  to select **HS Screening**.
-  Press **MENU/OK**  to confirm.
-  Press **UP**  or **DOWN**  to select **On** or **Off**.
-  Press **MENU/OK**  to confirm your settings.

iDECT

iDECT C5i

Remote operation

- 1** Using a tone-dialling phone, dial your home number and wait for the answering machine to answer
- 2** When you hear the outgoing message, enter the 4-digit PIN code within 5 seconds.
The default code is 0000. For details of how to set a new code, see *the User Guide*.
- 3** The outgoing message will stop playing and you will hear a confirmation beep
- 4** Press to start message playback
- 5** You can also use other keys as follows

| | | | |
|--|-----------|---|-----------|
| Replay from the start of the message | 1 | Start recording MEMO | 63 |
| Skip back to the previous message | 11 | Stop recording | 5 |
| Skip forward to the next message | 3 | Switch the answering machine On (Answ. & Rec.), Announce (Answer Only), Off | 8 |
| Delete single message during replaying Delete all message after replaying | 02 | | |
| Start recording OGM1 | 61 | Play all message/Replay continue | 2 |
| Start recording OGM2 | 62 | Only play new message | *2 |
| Play OGM1 | 71 | Pause | 5 |
| Play OGM2 | 72 | Stop replay | 55 |

Troubleshooting

ALWAYS confirm that:

- You have followed all the steps listed in the user manual to install and set up your telephone.
- All connectors are firmly inserted into their sockets.
- Mains power to the base unit is switched on.
- The handset's batteries are correctly and securely installed and are not run down.

Everyday use

"I cannot make or answer calls"

If the handset's display is blank, the phone may have been switched off. Press and hold **HANG-UP**  to switch it back on.

Check that the power adapter of the base unit is connected and the power is switched on.

The base unit needs mains power for normal operation of the phone - not just for charging the batteries.

Make sure that you are using the telephone cable that is supplied with your phone. Other telephone cables might not work. Move the handset closer to the base unit.

Check the battery level icon on the display. If it is low, replace the handset on the base unit or charging pod to recharge the batteries.

Switch off the power at the mains socket, wait for a short while and then switch it back on. This may resolve the problem.

"I cannot make calls"

If the handset display shows **Keys Locked**, press and hold  to unlock it before you make a call. Only one handset can be connected to an external line at a time. If another handset is already using the line, you need to wait until it has ended the call.

"When I press the keys, nothing happens"

Make sure that the batteries are installed in your handset. If the Battery Level icon on the display shows 'low', place your handset back on the cradle to charge.

| | |
|---|--|
| "When I enter a number, it appears on the display, but I cannot make an external call" | <p>Try to install the base unit in another location- somewhere higher if possible, or further away from other electrical equipment.</p> <p>Try moving the handset closer to the base unit.</p> |
| "The phone does not ring" | <p>Check that the power adapter of the base unit has been connected and the power is switched on.</p> <p>The base unit needs mains power for normal operation of the phone - not just for charging the batteries.</p> <p>Make sure that you are using the telephone cable that is supplied with your package.</p> |
| "My call was cut off when I move out of range. Now I can't use my handset." | <p>Move the handset closer to the base unit before you try to make a call again.</p> |
| "There is interference and noise on the line" | <p>Move the handset closer to the base unit, or try from a different position.</p> <p>Try to move the base unit away from other electrical equipment, such as television or computer. You can get the best reception if you place the base unit as high as possible. For example, in a two-storey house, the top floor is an ideal location to install your base unit.</p> |
| "I hear 'beeps' from my handset when I'm on a call" | <p>You may be moving out of range of the base unit. Move closer or your call may be cut off.</p> <p>Check the Battery Level icon on the display. If it is low, recharge the batteries.</p> |
| "The Caller Display feature isn't working" | <p>You need to subscribe to the Caller Display feature from your network service provider. You should be able to find the contact details on your phone bill. The caller may have withheld their number by dialling 141. Or they may be calling from a network that does not transmit caller's number (e.g. if it is an international call).</p> |
| "When I try to make a call, I hear a busy tone" | <p>If you are using a multi-handset system, check whether another handset is already on a call.</p> |
| "The volume in the earpiece is low when I'm on a call" | <p>Make sure that you are holding the earpiece correctly over your ear.</p> <p>Adjust the volume using the navigation key.</p> |

Intercom and transfer

"I can't transfer a call"

Make sure the other handset is within range of the base unit. Make sure that you have dialled the correct number for the other handset.

Battery

"The handset's battery pack is running low within an hour or two"

Before you first use the handset, you should have left it on the base unit or charging pod for 15 hours to charge the batteries fully.

You may need to replace the batteries. Check the connection between the base unit and the mains power socket.

"I try to recharge the batteries but I still get a warning that they are low"

You need to replace the batteries.

Dispose of used batteries safely - never burn them, or dispose them where they could get punctured.

Do not use non-rechargeable batteries in your handset - they may explode and cause damage.

If the fault persists...

Disconnect all other devices connected to the same line and try to make a call.

Disconnect the base unit from the telephone line and plug a different phone into the master telephone socket. Try to make a call. If this works, the line is OK.

If the call does not work, and you are using a two-way socket adaptor, remove it and plug a telephone directly into the socket. If the call now works, the adaptor may be faulty.

If you cannot make a call, the fault may be on the exchange line. Contact your service provider.

Cleaning and care

- **Do not clean** any part of your iDECT C5i with benzene, thinner or other solvent chemicals as this may cause permanent damage which is not covered by the Guarantee. If necessary, **clean it with a damp cloth**.
- Keep your iDECT C5i away from **hot, humid conditions** or **strong sunlight**, and **don't let it get wet**.
- Every effort has been made to ensure high standards of reliability for your iDECT C5i. However, if something does go wrong, please **do not try to repair it yourself**. Consult your supplier or the IDECT Helpline.

Declaration of conformity

NOTE: In compliance with Directive 2002/96/EC, when you purchase a product that comes with the symbol shown on the right, you are required to dispose the electrical and electronic equipment by separate waste collection and you cannot dispose of the product as normal waste. This equipment and all its components, subsystems and consumable materials formed an integral part of this product and when you decide to dispose them, you have to bring them to the local recycling centres for appropriate waste disposal, in compliance with the current regulations. Details about the location of these centres can be obtained from your local authority.



EC Declaration of Conformity

We the manufacturer / Importer : Binatone Telecom Plc
1 Apsley Way London
NW2 7HF, United Kingdom.

Declare under our sole responsibility that the following product

Type of equipment: Digital cordless telephone
Model Name: C5 and C5i Series

Country of Origin: China
Brand: Binatone

complies with the essential protection requirements of R&TTE Directive 1999/5/EC on the approximation of the laws of the Member States relating to **Radio Spectrum Matters**, the Council Directive 2004/108/EC on the approximation of the laws of the Member States relating to **electromagnetic compatibility (EMC)** and the European Community Directive 2006/95/EC relating to **Electrical Safety**.

Assessment of compliance of the product with the requirements relating to the essential requirements according to Article 3 R&TTE was based on Annex III of the Directive 1999/5/EC and the following standard:

Radio Spectrum: EN 301406: V1.5.1:2003;
EMC: EN 301489-1:V1.8.1:2008;
EN 301489-6:V1.3.1;2008;
Electrical Safety: EN 60950-1:2006

The product is labelled with the European Approval Marking CE as show. Any Unauthorized modification of the product voids this Declaration.



Manufacturer / Importer
(Signature of authorized person)



Signature: (K.H.Mueller, CT0)

London, 6 Oct 2009

Place & Date:

Guarantee and service

The iDECT C5i is guaranteed for 12 months from the date of purchase shown on your sales receipt. This guarantee does not cover any faults or defects caused by accidents, misuse, normal wear and tear, neglect, faults on the telephone line, lightning, tampering with the equipment, or any attempt at adjustment or repair other than through approved agents.

Please keep your sales (till) receipt — as this is your guarantee. You should also keep the original packaging.

In the unlikely event that you need to return your iDECT C5i to our Repair Centre while it is under guarantee, there may be a handling charge.

While the unit is under Guarantee

- 1** Disconnect the base unit from the telephone line and the mains electricity supply.
- 2** Pack up all parts of your iDECT C5i in their original packaging. Remember to include the mains power adapter.
- 3** Return the unit to the shop where you purchased it, making sure that you take along your sales receipt.

After the Guarantee has expired

- If the unit is no longer under Guarantee, firstly, follow steps **1** and **2** above for repair under Guarantee. Then...
- 3** Call our Service Department on **0845 345 9677** and ask for a quotation for the repair charge and details on where to send your iDECT C5i for repair.
 - 4** Make sure that you include with your iDECT C5i:
 - Your name and address
 - A cheque or postal order for the value of the repair. A brief description of the fault.
 - 5** Return your iDECT C5i to the address given by the Service Department.

Technical details

| | |
|--------------------------|--|
| Standard | Digital Enhanced Cordless Telecommunication (DECT) |
| Frequency | 1.8 GHz |
| Channel bandwidth | 1.728 MHz |
| Operating range | Up to 300m outdoors; up to 50m indoors |
| Operating time | Standby: 100 hours Talking: 10 hours Battery charge time: 15 hours |
| Temperature range | Operating 0°C to 40°C Storage -20°C to 60°C |

Caution

Risk of explosion if battery is replaced by an incorrect type.
Dispose of used batteries according to the instructions.

Power adaptor information

Base unit:

Electronic Sales Ltd. - IA5060B (UK) or IA5060G (VDE) -
input 100-240VAC 50-60Hz 0.2A, output 6VDC 500mA

Charger unit:

Electronic Sales Ltd. - IA1560B (UK) or IW1560G (VDE) -
input 100-240VAC 50-60Hz 0.2A, output 6VDC 150mA

Battery information

Hunan Corun Hi-Tech Co. Ltd. - Model Ni-MH AAAJ550 (rechargeable battery), Voltage Rating 2x1.2V AAA size 550mAh Ni-MH
Sanik Battery Co. Ltd. - Model SN-AAA55HJ (rechargeable battery), Voltage Rating 2x1.2V AAA size 550mAh Ni-MH

Port specification

The  port (connect to the mains power supply) is a SELV port with respect to EN41003.

The  port (connected to the telephone line) is a TNV port with respect to EN41003.