



Nortel Ethernet Routing Switch 5500 Series

Installation

Document status: Standard
Document version: 03.02
Document date: 16 December 2008

Copyright © 2005 - 2008 , Nortel Networks
All Rights Reserved.

The information in this document is subject to change without notice. The statements, configurations, technical data, and recommendations in this document are believed to be accurate and reliable, but are presented without express or implied warranty. Users must take full responsibility for their applications of any products specified in this document. The information in this document is proprietary to Nortel Networks Inc.

The software described in this document is furnished under a license agreement and may be used only in accordance with the terms of that license.

Restricted rights legend

Use, duplication, or disclosure by the United States Government is subject to restrictions as set forth in subparagraph (c)(1)(ii) of the Rights in Technical Data and Computer Software clause at DFARS 252.227-7013.

Notwithstanding any other license agreement that may pertain to, or accompany the delivery of, this computer software, the rights of the United States Government regarding its use, reproduction, and disclosure are as set forth in the Commercial Computer Software-Restricted Rights clause at FAR 52.227-19.

Statement of conditions

In the interest of improving internal design, operational function, and/or reliability, Nortel Networks reserves the right to make changes to the products described in this document without notice.

Nortel Networks does not assume any liability that may occur due to the use or application of the product(s) or circuit layout(s) described herein.

International regulatory statements of conformity

This is to certify that the Nortel Networks Ethernet Routing Switch 5500 Series was evaluated to the international regulatory standards for electromagnetic compliance (EMC) and safety and were found to have met the requirements for the following international standards:

- EMC - Electromagnetic Emissions - CISPR 22, Class A
- EMC - Electromagnetic Immunity - CISPR 24
- Electrical Safety - IEC 60950, with CB member national deviations

Further, the equipment has been certified as compliant with the national standards as detailed below.

National electromagnetic compliance (EMC) statements of compliance FCC statement (USA Only)

This equipment has been tested and found to comply with the limits for a Class A digital device, pursuant to Part 15 of the Federal Communications Commission (FCC) rules. These limits are designed to provide reasonable protection against harmful interference when the equipment is operated in a commercial environment. This equipment generates, uses, and can radiate radio frequency energy. If it is not installed and used in accordance with the instruction manual, it may cause harmful interference to radio communications. Operation of this equipment in a residential area is likely to cause harmful interference, in which case users will be required to take whatever measures may be necessary to correct the interference at their own expense.

ICES statement (Canada only)

Canadian Department of Communications Radio Interference Regulations

This digital apparatus (Nortel Ethernet Routing Switch 5500 Series) does not exceed the Class A limits for radio-noise emissions from digital apparatus as set out in the Radio Interference Regulations of the Canadian Department of Communications.

Règlement sur le brouillage radioélectrique du ministère des Communications

Cet appareil numérique (Nortel Ethernet Routing Switch 5500 Series) respecte les limites de bruits radioélectriques visant les appareils numériques de classe A prescrites dans le Règlement sur le brouillage radioélectrique du ministère des Communications du Canada.

CE marking statement (Europe only)

EN 55 022 statements

This is to certify that the Nortel Ethernet Routing Switch 5500 Series are shielded against the generation of radio interference in accordance with the application of Council Directive 89/336/EEC. Conformity is declared by the application of EN 55 022 Class A (CISPR 22).



CAUTION

This device is a Class A product. In a domestic environment, this device can cause radio interference, in which case the user may be required to take appropriate measures.

EN 55024 statement

This is to certify that the Nortel Ethernet Routing Switch 5500 Series are shielded against the susceptibility to radio interference in accordance with the application of Council Directive 89/336/EEC. Conformity is declared by the application of EN 55 024 (CISPR 24).

EN 300386 statement

The Ethernet Routing switch 5500 Series complies with the requirements of EN 300386 V1.3.1 for emissions and for immunity for a Class A device intended for use in either Telecommunications centre or locations other than telecommunications centres given the performance criteria as specified by the manufacturer.

European Union and European Free Trade Association (EFTA) notice



All products labeled with the CE marking comply with R&TTE Directive (1995/5/EEC) which includes the Electromagnetic Compliance (EMC) Directive (89/336/EEC) and the Low Voltage Directive (73/336/EEC) issued by the Commission of the European Community.

Compliance with these directives implies conformity to the following European Norms (ENs). The equivalent international standards are listed in parenthesis.

- EN 55022 (CISPR 22)–Electromagnetic Interference
- EN 55024 (IEC 61000-4-2, -3, -4, -5, -6, -8, -11)–Electromagnetic Immunity
- EN 61000-3-2 (IEC 61000-3-2)–Power Line Harmonics
- EN 61000-3-3 (IEC 61000-3-3)–Power Line Flicker

VCCI statement (Japan/Nippon only)

This is a Class A product based on the standard of the Voluntary Control Council for Interference (VCCI) for information technology equipment. If this equipment is used in a domestic environment, radio disturbance may arise. When such trouble occurs, the user may be required to take corrective actions.

この装置は、情報処理装置等電波障害自主規制協議会（VCCI）の基準に基づくクラスA情報技術装置です。この装置を家庭環境で使用すると電波妨害を引き起こすことがあります。この場合には使用者が適切な対策を講ずるよう要求されることがあります。

BSMI statement (Taiwan only)

This is a Class A product based on the standard of the Bureau of Standards, Metrology and Inspection (BSMI) CNS 13438, Class A.

警告使用者：

這是甲類的資訊產品，在居住的環境中使用時，可能會造成射頻干擾，在這種情況下，使用者會被要求採取某些適當的對策。

MIC notice (Republic of Korea only)

This device has been approved for use in Business applications only per the Class A requirements of the Republic of Korea Ministry of Information and Communications (MIC). This device may not be sold for use in a non-business application.

Observe the Regulatory Marking label on the bottom surface of the chassis for specific certification information pertaining to this model. Each model in the Nortel Ethernet Routing Switch 5500 Series which is approved for shipment to/usage in Korea is labeled as such, with all appropriate text and the appropriate MIC reference number.

National safety statements of compliance

EN 60 950 statement

This is to certify that the Nortel Ethernet Routing Switch 5500 Series are in compliance with the requirements of EN 60 950 in accordance with the Low Voltage Directive. Additional national differences for all European Union countries have been evaluated for compliance.

NOM statement (Mexico only)

The following information is provided on the devices described in this document in compliance with the safety requirements of the Norma Oficial Mexicana (NOM):

Exporter:	Nortel Networks, Inc. 4655 Great America Parkway Santa Clara CA 95054 USA
Importer:	Nortel Networks de México, S.A. de C.V. Avenida Insurgentes Sur #1605 Piso 30, Oficina Col. San Jose Insurgentes Deleg-Benito Juarez México D.F. 03900
Tel:	52 5 480 2100
Fax:	52 5 480 2199
Input:	Nortel Ethernet Routing Switch 5510 / 5530 100 - 240 VAC, 50/60 Hz, 1.3 A max Nortel Ethernet Routing Switch 5520 100 - 240 VAC, 50/60 Hz, 6.5 A max

Información NOM (unicamente para México)

La información siguiente se proporciona en el dispositivo o en los dispositivos descritos en este documento, en cumplimiento con los requisitos de la Norma Oficial Mexicana (NOM):

Exportador: Nortel Networks, Inc.
4655 Great America Parkway
Santa Clara, CA 95054 USA

Importador: Nortel Networks de México, S.A. de C.V.
Avenida Insurgentes Sur #1605
Piso 30, Oficina
Col. San Jose Insurgentes
Deleg-Benito Juarez
México D.F. 03900

Tel: 52 5 480 2100

Fax: 52 5 480 2199

Embarcar a: Nortel Ethernet Routing Switch 5510 / 5530
100 - 240 VAC, 50/60 Hz, 1.3 A max
Nortel Ethernet Routing Switch 5520
100 - 240 VAC, 50/60 Hz, 6.5 A max

Denan statement (Japan/Nippon only)

警告

本製品を安全にご使用頂くため、以下のことにご注意ください。

- 接続ケーブル、電源コード、ACアダプタなどの部品は、必ず製品に同梱されております添付品または指定品をご使用ください。添付品・指定品以外の部品をご使用になると故障や動作不良、火災の原因となることがあります。
- 同梱されております付属の電源コードを他の機器には使用しないでください。上記注意事項を守らないと、死亡や大怪我など人身事故の原因となることがあります。

National Environmental Statements of Compliance

The WEEE Directive 2002/96/EC and RoHS (Restriction of Hazardous Substances) Directive 2002/95/EC sets collection, recycling and recovery targets for various categories of electrical products and their waste.

Restriction on Hazardous Substances Directive Compliance Statement

The Restriction on Hazardous Substances Directive (RoHS) (2002/95/EC), which accompanies the WEEE Directive, bans the use of heavy metals and brominated flame-retardants in the manufacture of electrical and electronic equipment. Specifically, restricted materials under the RoHS Directive are Lead (including solder used in PCB's), Cadmium, Mercury, Hexavalent Chromium, and Bromine.

Nortel declares compliance with the European Union (EU) RoHS Directive (2002/95/EC).

WEEE Directive Compliance Statement



This product at end of life is subject to separate collection and treatment in the EU Member States, Norway, and Switzerland and therefore is marked with the symbol shown at the left. Treatment applied at end of life of these products in these countries shall comply with the applicable national laws implementing Directive 2002/96/EC on Waste of Electrical and Electronic Equipment (WEEE).

Nortel declares compliance with the European Union (EU) WEEE Directive (2002/96/EC).

Revision History

Date Revised	Version	Reason for revision
May 2005	1.00	New document for Software Release 4.2
July 2006	2.00	Updated document for Software Release 5.0
August 2007	3.01	Updated document for Software Release 5.1
December 2008	3.02	Updated document for Software Release 5.1

8 Revision History

Nortel Ethernet Routing Switch 5500 Series
Installation
NN47200-300 03.02 Standard
5.1 16 December 2008

Contents

Preface	11
Nortel Ethernet Routing Switch 5500 Series	11
Related publications	12
Finding the latest updates on the Nortel web site	13
How to get help	13
Installing the Nortel Ethernet Routing Switch	15
Phone Dongle Part Number	16
Electrostatic discharge	16
Preventing electrostatic discharge damage	16
Preventing electrostatic damage in new cable installations	16
Environmental requirements	17
Package contents	19
Installing the Nortel Ethernet Routing Switch 5500 Series on a table or shelf	20
Installing the Nortel Ethernet Routing Switch 5500 Series in an equipment rack	21
Installing a Nortel Ethernet Routing Switch 5530-24TFD in a rear mounted configuration	23
Cabling requirements for the Nortel Ethernet Routing Switch 5500 Series	24
Installation and removal of SFP and XFP transceivers	25
Installation of SFP and XFP transceivers	25
Removal of SFP and XFP transceivers	26
RJ-45 connector pin assignments	27
Nortel Ethernet Routing Switch 5510 and 5530	28
Nortel Ethernet Routing Switch 5520-24T-PWR and 5520-48T-PWR	28
Console port pin assignments	29
Universal Serial Bus (USB) ports (5530-24TFD only)	29
Power specifications for the Nortel Ethernet Routing Switch 5500 Series	30
Nortel Ethernet Routing Switch 5510-24T and 5510-48T	30
Nortel Ethernet Routing Switch 5520-24T-PWR and 5520-48T-PWR	30
Nortel Ethernet Routing Switch 5530-24TFD	31
Nortel Ethernet Power Supply 10 power specification	32
Nortel Ethernet Redundant Power Supply 15 power specification	32
Nortel Ethernet DC-DC converter module	32
Connecting AC power	32

- Power cord specifications 32
- Connecting power to the back panel 33
- Checking LEDs on the Nortel Ethernet Routing Switch 5500 Series 34
 - Front panel LEDs 34
 - Switch LED state indicators 36
 - Port LED state indicators 38
 - Shared SFP transceiver port LED state indicators 39
 - XFP transceiver port LED indicators (5530-24TFD only) 39
- Setting IP parameters for the Nortel Ethernet Routing Switch 5500 Series 40
 - Setting IP parameters using the console port and Console Menu 41
 - Setting IP Parameters using the console port and CLI 44
 - Setting IP parameters using the Web-based Management Interface 47
 - Setting IP parameters using the UI button 48
- Nortel Ethernet Routing Switch 5500 Series Stack Configuration 49
 - Stack connector 49
 - Stack configuration 51
 - Initial installation 54
 - Stack MAC address 54
 - Temporary base unit 54
 - Removing a stack unit 55
 - Replacing a stack unit 55
 - Stack configurations 56
 - Redundant cascade stacking 59

Translations of safety messages

Preface

This guide provides information and instructions on the proper installation of a 5500 Series Nortel Ethernet Routing Switch. Please consult any documentation included with the switch and the product release notes (see "[Related publications](#)" (page 12) for any errata before beginning the installation procedure.

To successfully accomplish the installation procedures outlined in this document, the following tools or equipment are required:

- #2 Phillips screwdriver
- An AC power cord that meets the requirements of the appropriate, local electrical codes. See "[Connecting AC power](#)" (page 32) for more information on this topic.
- A console cable and connector to match the male DTE connector (DB-9) on the switch.

Nortel Ethernet Routing Switch 5500 Series

"[5500 Series Switch Platforms](#)" (page 11) outlines the switches that are part of the 5500 Series of Nortel Ethernet Routing Switches

5500 Series Switch Platforms

5500 Series Switch Model	Key Features
Nortel Ethernet Routing Switch 5510-24T	A 24 port, 10/100/1GBase-T, Layer 4, diffserv-capable, stackable Ethernet switch. This switch contains two Shared SFP Transceiver Ports.
Nortel Ethernet Routing Switch 5510-48T	A 48 port, 10/100/1GBase-T, Layer 4, diffserv-capable, stackable Ethernet switch. This switch contains two Shared SFP Transceiver Ports.
Nortel Ethernet Routing Switch 5520-24T-PWR	A 24 port, 10/100/1GBase-T, Layer 4, diffserv-capable, stackable Ethernet switch with full Power over Ethernet (PoE) capability 3 (802.3af) on all copper ports. This switch contains four Shared SFP Transceiver Ports.

5500 Series Switch Model	Key Features
Nortel Ethernet Routing Switch 5520-48T-PWR	A 48 port, 10/100/1GBase-T, Layer 4, diffserv-capable, stackable Ethernet switch with full Power over Ethernet (PoE) capability 3 (802.3af) on all copper ports. This switch contains four Shared SFP Transceiver Ports.
Nortel Ethernet Routing Switch 5530-24TFD	A 24 port, 10/100/1GBase-T, Layer 4, diffserv-capable, stackable Ethernet switch. This switch contains twelve Shared SFP Transceiver Ports and two XFP Transceiver Ports.

Related publications

For more information about the management, configuration, and usage of the Nortel Ethernet Routing Switch 5500 Series, refer to the publications listed in "[Nortel Ethernet Routing Switch 5500 Series Documentation](#)" (page 12)

Nortel Ethernet Routing Switch 5500 Series Documentation

Title	Description	Part Number
<i>Nortel Ethernet Routing Switch 5500 Series Release 5.1 Installation</i>	Instructions for the installation of a switch in the Nortel Ethernet Routing Switch 5500 Series. It also provides an overview of hardware key to the installation, configuration, and maintenance of the switch.	NN47200-300
<i>Nortel Ethernet Routing Switch 5500 Series Release 5.1 Configuration - System</i>	Instructions for the general configuration of switches in the 5500 Series that are not covered by the other documentation.	NN47200-500
<i>Nortel Ethernet Routing Switch 5500 Series Release 5.1 Configuration - Security -</i>	Instructions for the configuration and management of security for switches in the 5500 Series.	NN47200-501
<i>Nortel Ethernet Routing Switch 5500 Series Release 5.1 Configuration - VLANs, Spanning Tree, and Link Aggregation</i>	Instructions for the configuration of spanning and trunking protocols on 5500 Series switches	NN47200-502

Title	Description	Part Number
<i>Nortel Ethernet Routing Switch 5500 Series Release 5.1 Configuration - IP Routing Protocols</i>	Instructions on the configuration of IP routing protocols on 5500 Series switches.	NN47200-503
<i>Nortel Ethernet Routing Switch 5500 Series Release 5.1 Configuration - Quality of Service</i>	Instructions on the configuration and implementation of QoS and filtering on 5500 Series switches.	NN47200-504
<i>Nortel Ethernet Routing Switch 5500 Series Release 5.1 Configuration - System Monitoring</i>	Instructions on the configuration, implementation, and usage of system monitoring on 5500 Series switches.	NN47200-505
<i>Nortel Ethernet Routing Switch 5500 Series Release Notes - Software Release 5.1</i>	Provides an overview of new features, fixes, and limitations of the 5500 Series switches. Also included are any supplementary documentation and document errata	NN47200-400
<i>Installing the Nortel Ethernet Redundant Power Supply 15</i>	Instructions for the installation and usage of the Nortel Ethernet RPS 15.	217070-A
<i>DC-DC Converter Module for the Baystack 5000 Series Switch</i>	Instructions for the installation and usage of the DC-DC power converter.	215081-A
<i>Nortel Ethernet Routing Switch 5500 Series Installation - SFP</i>	Instructions for the installation and usage of SFP and XFP transceivers and GBICs.	NN47200-302

Finding the latest updates on the Nortel web site

The content of this documentation was current at the time of release. To check for updates to the documentation and software for the Nortel Ethernet Routing Switch 5500 Series, go to the Nortel Web site and use the Product Finder to select the Nortel Ethernet Routing Switch 5500 Series products. See "[How to get help](#)" (page 13) for the link to the Nortel support portal.

How to get help

If a service contract for the Nortel product has been purchased from a distributor or authorized reseller, contact the technical support staff for that distributor or reseller for assistance.

If a Nortel service program was purchased, contact Nortel Technical Support.

The following information is available online:

- contact information for Nortel Technical Support
- information about the Nortel Technical Solutions Centers
- information about the Express Routing Code (ERC) for your product

An ERC is available for many Nortel products and services. When an ERC is used, the call is routed to technical support personnel who specialize in supporting the service or product. The ERC for a particular product or service is available online.

The main Nortel support portal is available at <http://www.nortel.com/support>.

Installing the Nortel Ethernet Routing Switch

This section describes the information and procedures used for installing the Nortel Ethernet Routing Switch 5500 Series. Unless otherwise noted, tasks outlined in this section are applicable to all switches in this series.

The following topics are covered in this section:

- "Phone Dongle Part Number" (page 16)
- "Electrostatic discharge" (page 16)
- "Environmental requirements" (page 17)
- "Package contents" (page 19)
- "Installing the Nortel Ethernet Routing Switch 5500 Series on a table or shelf" (page 20)
- "Installing the Nortel Ethernet Routing Switch 5500 Series in an equipment rack" (page 21)
- "Cabling requirements for the Nortel Ethernet Routing Switch 5500 Series" (page 24)
- "RJ-45 connector pin assignments" (page 27)
- "Console port pin assignments" (page 29)
- "Universal Serial Bus (USB) ports (5530-24TFD only)" (page 29)
- "Power specifications for the Nortel Ethernet Routing Switch 5500 Series" (page 30)
- "Connecting AC power" (page 32)
- "Checking LEDs on the Nortel Ethernet Routing Switch 5500 Series" (page 34)
- "Setting IP parameters for the Nortel Ethernet Routing Switch 5500 Series" (page 40)

Phone Dongle Part Number

The part number for the Nortel Ethernet Routing Switch 5520 (5520-24T/48T-PWR) universal phone dongle is DY4311046

Electrostatic discharge

This section provides information and procedures for the prevention of electrostatic discharge during the installation process.

Preventing electrostatic discharge damage

Electrostatic discharge (ESD) is a discharge of stored static electricity that can damage equipment and impair electrical circuitry. These electrostatic voltages can result from friction, including, but not exclusive to, pulling cabling through conduits, walking across carpeted areas, and building up of static charge in clothing. ESD damage occurs when electronic components are improperly handled and can result in complete or intermittent failures. While networking equipment is commonly designed and tested to withstand common mode ESD events, voltage sometimes can be discharged to some connector pins but not others, or to some pins before others, which has the potential to damage the networking equipment.

To protect the Nortel Ethernet Routing Switch against ESD damage, take the following preventive measures before connecting any data cables to the device:

- Always use anti-static wrist straps. Make sure the strap is adjusted to provide good skin contact.
- Ensure that work surfaces and equipment racks are properly grounded for protection against electrostatic discharge. The common point must be connected to the building ground wire. In a properly wired building, the nearest reliable ground is typically at the electrical outlet.
- Avoid contact between equipment and clothing. The wrist or ankle strap only protects the equipment from ESD voltages on the body; ESD voltages on clothing can still cause damage.
- Avoid touching any connector pins.
- Do not remove the wrist or ankle strap until the installation is complete.

Preventing electrostatic damage in new cable installations

With new cable installations, Nortel recommends that the use of an ESD discharge cable to reduce the potential for damage from static that can build up in cables. An example of such a cable is illustrated below.

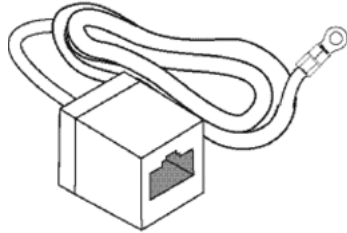
ESD cable example

To install the ESD discharge cable:

Step	Action
1	Connect the ground lug on the ESD discharge cable to a safe and suitable earth ground.
2	Briefly connect all RJ-45 cable connectors to the female RJ-45 connector of the ESD discharge cable, then connect each RJ-45 cable connector to the switch.
3	Leave cables connected to the networking equipment. Once cables are connected to networking equipment, the cables do not build up charge.

—End—

Environmental requirements

"Nortel Ethernet Routing Switch 5500 Series environmental requirements" (page 17) displays the environmental requirements for the individual switches in this series. Ensure that the area where the switch is installed and operated will meet these requirements.

Nortel Ethernet Routing Switch 5500 Series environmental requirements

	Nortel Ethernet Routing Switch 5510	Nortel Ethernet Routing Switch 5520	Nortel Ethernet Routing Switch 5530
Ambient Temperature	Between 32 and 113 degrees Fahrenheit (0 and 45 degrees Celsius).	Between 32 and 104 degrees Fahrenheit (0 and 40 degrees Celsius) for continuous operation. This operational temperature can	Between 32 and 122 degrees Fahrenheit (0 and 50 degrees Celsius) for continuous operation. This operational temperature can

	Nortel Ethernet Routing Switch 5510	Nortel Ethernet Routing Switch 5520	Nortel Ethernet Routing Switch 5530
		be extended to 131 degrees Fahrenheit (55 degrees Celsius) for short time operation.	be extended to 14 to 140 degrees Fahrenheit (-10 to 60 degrees Celsius) for short time operation.
Storage Temperature	Between -40 and 185 degrees Fahrenheit (-40 and 85 degrees Celsius).	Between -40 and 185 degrees Fahrenheit (-40 and 85 degrees Celsius).	Between -40 and 185 degrees Fahrenheit (-40 and 85 degrees Celsius).
Operating Relative Humidity	Between 5 and 85% non-condensing.	Between 10 and 90% non-condensing.	Between 10 and 90% non-condensing.
Storage Relative Humidity	Between 10 and 95% non-condensing.	Between 10 and 95% non-condensing.	Between 10 and 95% non-condensing.
Maximum Operating Altitude	10,000 feet (3048 meters) above sea level.	10,000 feet (3048 meters) above sea level.	15,000 feet (4572 meters) above sea level.
Storage Altitude	Between -1,000 and 10,000 feet (-304.8 and 3048 meters) above sea level.	Between -1,000 and 10,000 feet (-304.8 and 3048 meters) above sea level.	Between -1,000 and 40,000 feet (-340.8 and 12,192 meters) above sea level.
Miscellaneous Operating Considerations	<ul style="list-style-type: none"> • No heat sources such as hot air vents or direct sunlight located near the switch. • No sources of severe electromagnetic interference located near the switch. • No excessive dust in the environment. • An adequate power source is located within 6 feet (1.83 meters) of the switch. One 15-amp circuit is required for each power supply. • At least 2 inches (5.08 centimeters) of clearance on each side of the switch unit for ventilation. • Adequate clearance is allotted at the front and rear of the switch for access to cables. 		

**WARNING**

To avoid bodily injury from hazardous electrical shock and current, never remove the top of the device. There are no user-serviceable components inside. For a translation of this statement, see "Translations of safety messages" (page 61).

Package contents

"Nortel Ethernet Routing Switch 5500 Series package contents" (page 19) illustrates the components that are provided with each switch in the 5500 Series. Should any components be missing, contact the vendor from which the switch was purchased.

Nortel Ethernet Routing Switch 5500 Series package contents

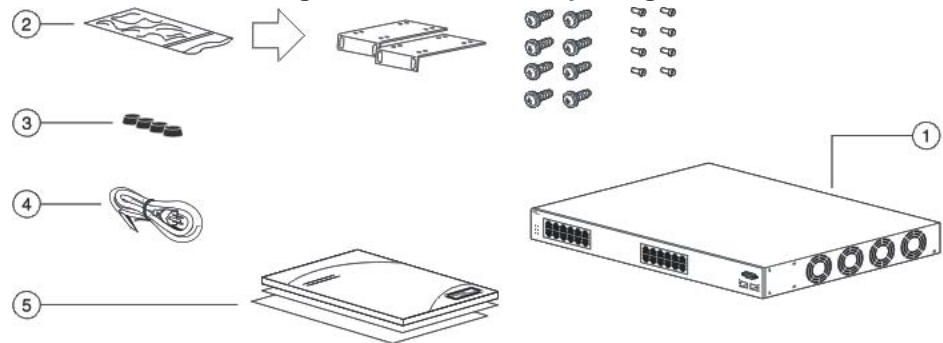

1. Nortel Ethernet Routing Switch 5500 Series
2. Rack-mounting hardware that includes:
 - Rack-mount brackets
 - The Nortel Ethernet Routing Switch 5530-24TFD offers 24 inch rack mounting brackets.
 - Screws for attaching brackets to the switch
 - Screws for attaching the switch to the equipment rack
 - Rubber footpads
3. AC power cord
4. Documentation

Installing the Nortel Ethernet Routing Switch 5500 Series on a table or shelf

A single 5500 Series Nortel Ethernet Routing Switch can be installed on any flat surface. The surface should ideally be able to support the combined weight of the switch and attached cables; between 15 and 20 pounds (7 to 9 kilograms).



CAUTION

Do not place a Nortel Ethernet Power Supply Unit 10 or Nortel Ethernet Redundant Power Supply 15 on top of a Nortel Ethernet Routing Switch 5500 Series. The switch housing of a 5500 Series Nortel Ethernet Routing Switch is not strong enough to support the weight of these units. For a translation of this statement, see "Translations of safety messages" (page 61).

To install a 5500 Series switch on a table or shelf, follow this procedure:

Step	Action
------	--------

- | | |
|---|--|
| 1 | Attach the provided rubber footpads at the locations noted in "Attaching the rubber footpads" (page 20) on the bottom of the switch. |
|---|--|

Attaching the rubber footpads

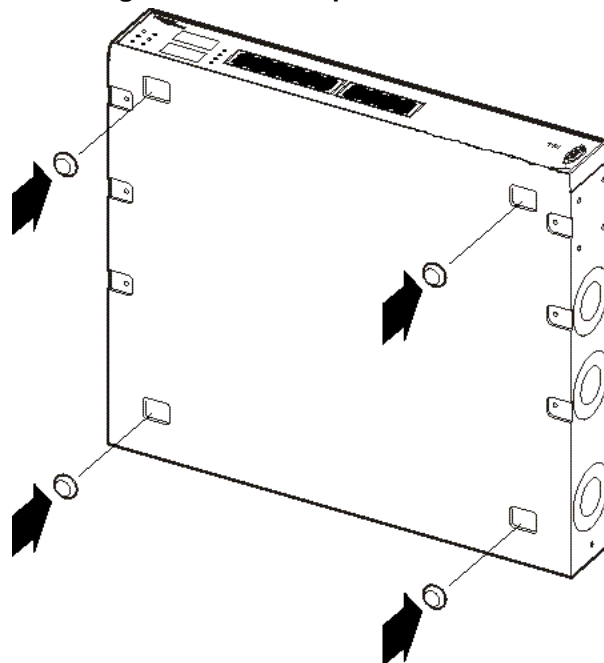

10753FC

- 2 Set the switch on a table or shelf as illustrated in "Nortel Ethernet Routing Switch on a desk or shelf" (page 21). Allow at least 2 inches (5.1 centimeters) on each side for proper ventilation and at least 5 inches (12.7 centimeters) at the back for power cord clearance.

Nortel Ethernet Routing Switch on a desk or shelf

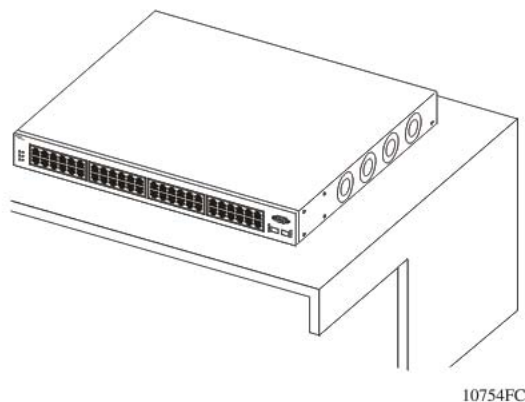

—End—

Installing the Nortel Ethernet Routing Switch 5500 Series in an equipment rack

Before beginning this procedure, ensure that the equipment rack the switch will be installed in meets these requirements:

- A space of 1.75 inches (4.45 centimeters) is provided for each switch in an EIA or IEC standard 19 inch (48.2 centimeter) equipment rack.
- The rack is bolted to the floor and braced if necessary.
- The rack is grounded to the same grounding electrode used by the power service in the area. The ground path must be permanent and must not exceed 1ohm of resistance from the rack to the grounding electrode.



CAUTION

When mounting the device in a rack, do not stack units directly on top of one another in the rack. Each unit must be secured to the rack with the appropriate mounting brackets. Mounting brackets are not designed to support multiple units. For a translation of this statement, see "Translations of safety messages" (page 61).

To install a 5500 Series switch in an equipment rack, follow this procedure:

Step	Action
------	--------

- 1 Attach a bracket to each side of the switch using a #2 Phillips screwdriver as illustrated in "Attaching switch brackets" (page 22). The bracket with the round holes goes on the right side of the switch, where the round fan vents are located.

Attaching switch brackets

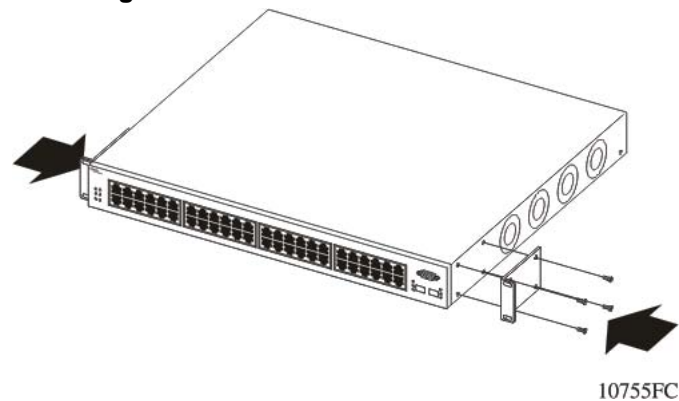

- 2 Slide the switch into the rack as illustrated in "Mounting the switch" (page 22). Insert and tighten the rack-mount screws with a #2 Phillips screwdriver.

Mounting the switch

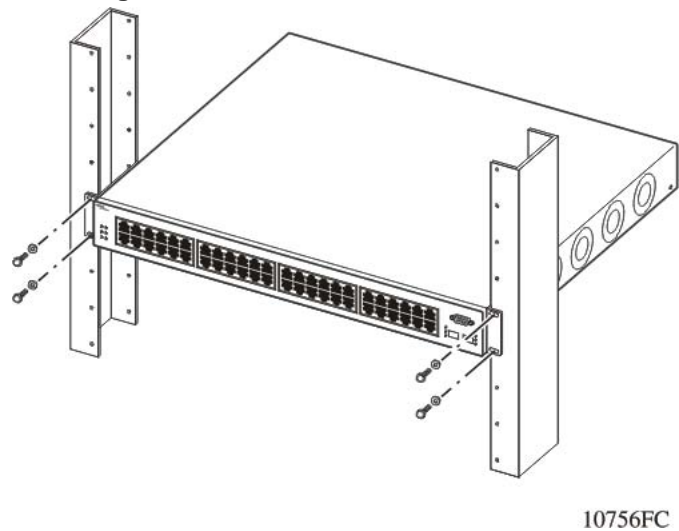

—End—

Installing a Nortel Ethernet Routing Switch 5530-24TFD in a rear mounted configuration

The Nortel Ethernet Routing Switch 5530-24TFD now features the option of installing the switch in a rear mounted configuration. This option allows the switch to be installed with the back panel facing forward.

To install the 5530-24TFD in a rear mounted configuration perform the following tasks:

Step	Action
------	--------

- 1 Attach a bracket to each side of the switch using a #2 Phillips screwdriver as illustrated in ["Attaching rear mounted switch brackets"](#) (page 23). The bracket with the round holes goes on the right side of the switch, where the round fan vents are located.

Attaching rear mounted switch brackets

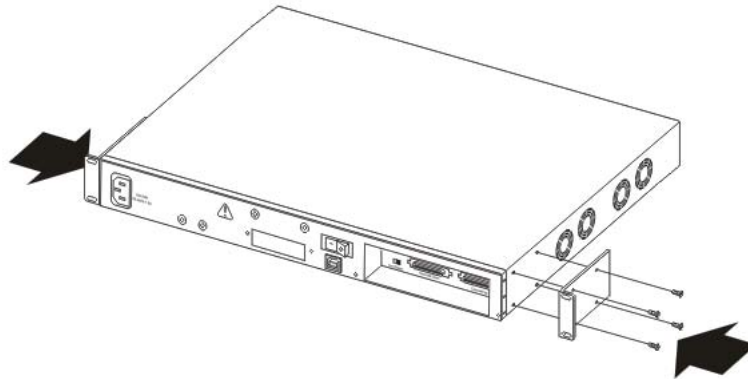

- 2 Slide the switch into the rack as illustrated in ["Rear mounted switch configuration"](#) (page 24). Insert and tighten the rack-mount screws with a #2 Phillips screwdriver.

Rear mounted switch configuration

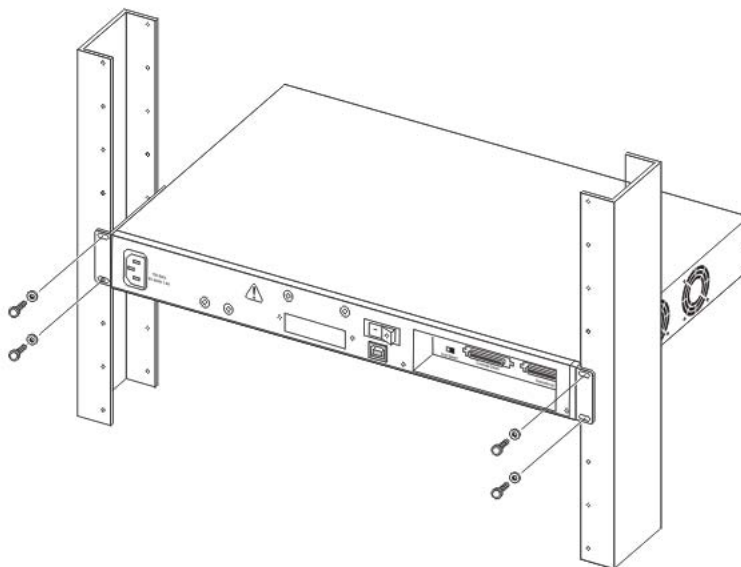

—End—

Cabling requirements for the Nortel Ethernet Routing Switch 5500 Series

"Switch cabling requirements" (page 24) outlines the required cables for a Nortel Ethernet Routing Switch 5500 Series and their specifications.

Switch cabling requirements

Required Cable	Description
10/100/1GBase-T Ports	The interconnect cabling must conform to the Cat5e, Cat6, or Cat6e specification of the Commercial Building Telecommunications Cabling Standard, ANSI/TIA/EIA 568-B fitted with an RJ-45 Module Jack.
Console Port	Serial cable with a DB-9 female connector on both ends. The maximum length for the console port cable is 25 feet (8.3 meters).
Shared SFP Transceiver Ports	Varies with the installed SFP Transceiver. Refer to the documentation that was shipped with the SFP Transceiver for specifications.

Required Cable	Description
XFP Transceiver Ports	Varies with the installed XFP Transceiver. Refer to the documentation that was shipped with the XFP Transceiver for specifications.
USB Ports	USB 2.0 compliant cable with a USB Type A connector on both ends.

Note: In **Autonegotiation** mode, the Nortel Ethernet Routing Switch 5500 Series automatically provides the proper MDI/MDI-X connection on the RJ-45 ports; thereby eliminating the need for crossover cables. When **Autonegotiation** is disabled on 10/100 ports, they are configured as an MDI-X connection.

Installation and removal of SFP and XFP transceivers

The following section outlines the installation and removal of SFP and XFP transceivers in the Nortel Ethernet Routing Switch 5500 Series. For complete coverage of SFP and XFP transceiver usage and designation, refer to *Installation - SFPs* (part number NN47200-302).

Installation of SFP and XFP transceivers

This section details the installation of SFP and XFP transceivers. To install these transceivers, use the following procedure:

Step	Action
1	Remove the transceiver from the protective packaging.
2	Verify that the transceiver is the correct model for the network configuration.
3	Grasp the transceiver between the thumb and forefinger.
4	Insert the transceiver into the proper module on the switch. Apply a light pressure to the transceiver until it clicks and locks into position in the module.

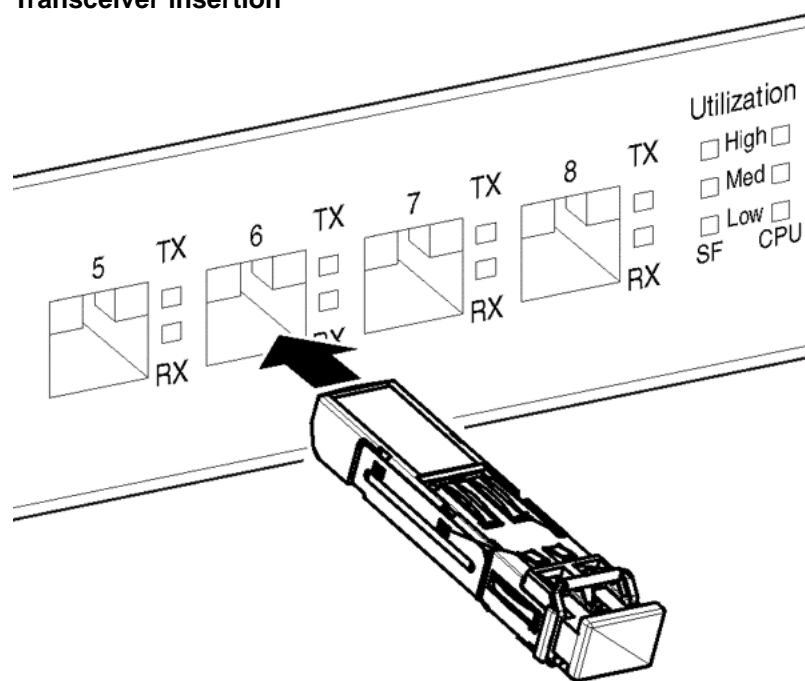
Transceiver insertion

- 5 Remove the dust cover from the transceiver optical bores.

—End—

Removal of SFP and XFP transceivers

This section details the removal of SFP and XFP transceivers. To remove these transceivers, use the following procedure:

Step	Action
------	--------

- | | |
|---|---|
| 1 | Disconnect the network fiber cable from the transceiver. |
| 2 | Use the locking/extractor mechanism on the transceiver to release it. The locking/extractor mechanism varies from model to model. |

Transceiver locking/extractor mechanism examples

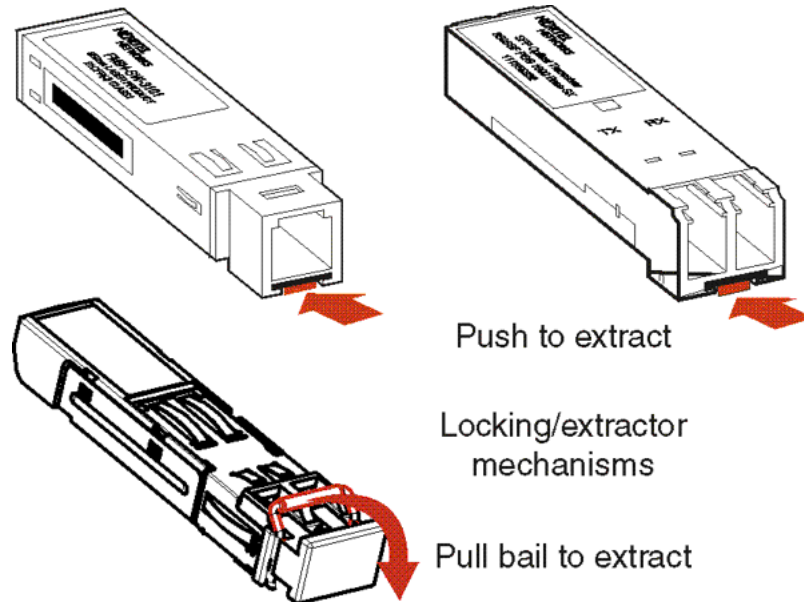

- 3 Slide the transceiver out of the module slot.
- 4 If the transceiver does not slide easily from the module slot, use a gentle side-to-side rocking motion while firmly pulling the transceiver from the slot.
- 5 Attach a dust cover over the fiber optic bores and store the transceiver in a safe place until needed.

Note: Transceivers should be discarded in accordance with the proper laws and regulations.

—End—

RJ-45 connector pin assignments

The following section outlines the connector pin assignments for the RJ-45 connectors in the Nortel Ethernet Routing Switch 5500 Series switches.

Consult the appropriate section for specific information on an individual switch:

- "Nortel Ethernet Routing Switch 5510 and 5530" (page 28)
- "Nortel Ethernet Routing Switch 5520-24T-PWR and 5520-48T-PWR" (page 28)

Nortel Ethernet Routing Switch 5510 and 5530

The following table outlines the RJ-45 connector pin assignments in the Nortel Ethernet Routing Switch 5510 and 5530 switches.

5510 RJ-45 connector pin assignments

Connector	Pin Number	Signal for 10/100Base-T MDI configuration	Signal for 10/100Base-T MDI-X configuration
 <small>B785K32 1</small> <small>0468EA</small>	1	Output transmit data + (TX+)	Input receive data + (RX+)
	2	Output transmit data - (TX-)	Input receive data - (RX-)
	3	Input receive data + (RX+)	Output transmit data + (TX+)
	6	Input receive data - (RX-)	Output transmit data - (TX-)
	4, 5, 7, 8	Not used	Not used
	Pin Number	Signal for 1GBase-T MDI configuration	Signal for 1GBase-T MDI-X configuration
	1	TP0+	TP1+
	2	TP0-	TP1-
	3	TP1+	TP0+
	4	TP2+	TP3+
	5	TP2-	TP3-
	6	TP1-	TP0-
	7	TP3+	TP2+
8	TP3-	TP2-	

Nortel Ethernet Routing Switch 5520-24T-PWR and 5520-48T-PWR

The following table outlines the RJ-45 connector pin assignments in the Nortel Ethernet Routing Switch 5520.

5520 RJ-45 connector pin assignments

Connector	Pin Number	Signal	Description
 <small>B785K32 1</small> <small>0468EA</small>	1	RX+/power+	Receive Data+/power+
	2	RX-/power+	Receive Data-/power+
	3	TX+/power-	Transmit Data+/power-
	4	Not applicable	Not applicable
	5	Not applicable	Not applicable
	6	TX-/power-	Transmit Data-/power-

Connector	Pin Number	Signal	Description
	7	Not applicable	Not applicable
	8	Not applicable	Not applicable

Note: The Nortel Ethernet Routing Switch 5520 uses pins 1, 2, 3, and 6 for the purposes of Power over Ethernet (PoE).

Console port pin assignments

" [Console port pin assignments](#)" (page 29) outlines the console port pin assignments in the Nortel Ethernet Routing Switch 5500 Series.

Console port pin assignments

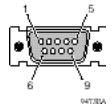
Connector	Pin Number	Signal
	1	Carrier detect (not used)
	2	Transmit Data (TXD)
	3	Receive Data (RXD)
	4	Data terminal ready (not used)
	5	Signal ground (GND)
	6	Not used
	7	Request to send (not used)
	8	Not used
	9	Ring indicator (not used)

Universal Serial Bus (USB) ports (5530-24TFD only)

The Nortel Ethernet Routing Switch 5530-24TFD features USB ports on the front panel adjacent to the console port and on the back panel. The addition of USB ports will enable switch administrators to perform tasks that were previously completed through TFTP with a commonly available USB Mass Storage Device ("flash drive" or "thumb drive"). These tasks include:

- Software Download
- Syslog Backup
- ASCII Configuration File Generation and Download

File and system operations will be limited by the size of the USB device in use.

Only USB drives that comply with the Mass Storage sub-section of the USB 1.1 and USB 2.0 specification are supported. Support is not extended to third-party devices that do not comply with these standards. Off-the-shelf

drives that do not comply with these standards may not operate with the 5530-24TFD switch. Consult the documentation provided with the USB drive to ensure compliance with these standards.

Note: The Nortel Ethernet Routing Switch 5530-24TFD also has a back panel USB port that is currently not enabled.

Power specifications for the Nortel Ethernet Routing Switch 5500 Series

The following section describes the power specifications for the switches in the 5500 Series. Consult the appropriate section below for specific information on the appropriate switch:

- "Nortel Ethernet Routing Switch 5510-24T and 5510-48T" (page 30)
- "Nortel Ethernet Routing Switch 5520-24T-PWR and 5520-48T-PWR" (page 30)
- "Nortel Ethernet Routing Switch 5530-24TFD" (page 31)

In addition, the switches in the 5500 Series can make use of redundant power supplies tailored specifically to their needs. For information on these units, see the sections listed below:

- "Nortel Ethernet Power Supply 10 power specification" (page 32)
- "Nortel Ethernet Redundant Power Supply 15 power specification" (page 32)
- "Nortel Ethernet DC-DC converter module" (page 32)

Nortel Ethernet Routing Switch 5510-24T and 5510-48T

The following are the power specifications for the Nortel Ethernet Routing Switch 5510.

AC power specifications

Input Current:	1.3 to 0.65A
Input Voltage (rms):	100 to 240 VAC at 47 to 63 Hz
Power Consumption:	135W
Thermal Rating	460 BTU/Hr maximum

Nortel Ethernet Routing Switch 5520-24T-PWR and 5520-48T-PWR

To provide DTE power to all 48 ports at 15.4W per port the Nortel Ethernet Routing Switch 5520 needs to use power from the Nortel Ethernet Redundant Power Supply 15 (RPS 15).

AC power specifications

Input Current:	6.5A at 115VAC or 3.25A at 230VAC
Input Voltage (rms):	100 to 240 VAC 50/60 Hz
Power Consumption:	600W maximum
Thermal Rating:	850 BTU/Hr
Inrush Current:	20A 120VAC at maximum load, 40A 240VAC at maximum load
Turn on Condition:	1 second maximum after application of AC power. Note: 12V output rise time, from 10% to 90%, shall be a maximum of 50 ms and monotonic under all defined input and output conditions.
Efficiency:	70% minimum

Nortel Ethernet Routing Switch 5530-24TFD

The following are the power specifications for the Nortel Ethernet Routing Switch 5530.

AC power specifications

Input Current:	1.7A at 120VAC or 0.85A at 240VAC
Input Voltage (rms):	100 to 240VAC 50/60 Hz
Typical Power Consumption:	125W
Typical Thermal Rating:	427 BTU/Hr
Maximum Power Consumption:	150W
Maximum Thermal Rating:	512 BTU/Hr
Inrush Current:	20A 120VAC at maximum load, 40A 240VAC at maximum load 1 second maximum after application of AC power.
Turn on Condition:	Note: 12V output rise time, from 10% to 90%, shall be a maximum of 50 ms and monotonic under all defined input and output conditions.
Efficiency:	70% minimum

Nortel Ethernet Power Supply 10 power specification

Output Current:	4.2A maximum
Output Voltage:	-48 VDC
Output Power:	200W maximum

Nortel Ethernet Redundant Power Supply 15 power specification

A DC power supply used with the AC power supply to provide DTE power to all of the PoE ports in the Nortel Ethernet Routing Switch 5520.

RPS power specifications

Input Voltage:	100 to 240 VAC 50/60 Hz
Input Current:	10A maximum
Inrush Current:	40A maximum (regardless of ambient temperature)
Output Voltage:	47.5 VDC
Output Current:	12.0A
Output Power:	600W

Nortel Ethernet DC-DC converter module





The Nortel Ethernet Routing Switch 5510 requires an additional DC-DC converter module to make use of the Nortel Ethernet Routing Switch Redundant Power Supply Model 15 (RPS 15). This module is required to connect the RPS 15 to the Nortel Ethernet Routing Switch 5510 but is not required for other switches in the 5500 Series. For information on connecting this module to the 5510, see *DC-DC Converter Module for the Baystack 5000 Series Switch* (Part Number 215081-A).

Connecting AC power

Power cord specifications

To connect AC power to the switch an appropriate AC power cord is required as outlined in the "Preface" (page 11). Refer to " [International power cord specifications](#)" (page 33) for plug specifications.

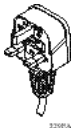
International power cord specifications

Country / Plug Specification	Specifications	Typical Plug
Continental Europe: <ul style="list-style-type: none"> CEE7 standard VII male plug Harmonized cord (HAR marking on the outside of the cord jacket to comply with the CENELEC Harmonized Document HD-21) 	<ul style="list-style-type: none"> 220 or 230 VAC 50 Hz Single Phase 	
United States of America / Canada / Japan: <ul style="list-style-type: none"> NEMA5-15P male plug UL-recognized (UL stamped on cord jacket) CSA-certified (CSA label secured to the cord) 	<ul style="list-style-type: none"> 100 or 120 VAC 50 - 60 Hz Single Phase 	
United Kingdom: <ul style="list-style-type: none"> BS1363 male plug with fuse Harmonized cord 	<ul style="list-style-type: none"> 240 VAC 50 Hz Single Phase 	
Australia: <ul style="list-style-type: none"> AS3112-1981 male plug 	<ul style="list-style-type: none"> 240 VAC 50 Hz Single Phase 	

**DANGER**

Use only power cords that have a grounding path. Without a proper ground, a person who touches the switch is in danger of receiving an electrical shock. Lack of a grounding path to the switch may result in excessive emissions. For a translation of this statement, see "[Translations of safety messages](#)" (page 61).

Connecting power to the back panel

Connect the AC power cord to the back of the switch and then connect the cord to an AC power outlet. "[Connecting AC power to the back panel](#)" (page 34) illustrates connecting the AC power cord to the switch back panel.

Note: The Nortel Ethernet Routing Switch 5500 Series do not have an AC power switch. When the power cord is connected to a suitable AC power outlet, the switch powers up immediately.

Connecting AC power to the back panel

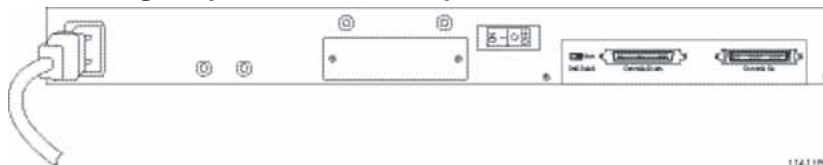

WARNING

Disconnecting the AC power cord is the only way to turn off AC power to the Nortel Ethernet Routing Switch 5500 Series. Always connect the AC power cord in a location that can be reached quickly and safely in case of an emergency. For a translation of this statement, see ["Translations of safety messages"](#) (page 61).

Checking LEDs on the Nortel Ethernet Routing Switch 5500 Series

Refer to the illustrations and tables below for descriptions of the LEDs on the Nortel Ethernet Routing Switch 5500 Series. The tables describe LED operation for a switch that has completed the power-on self-test.

Front panel LEDs

["Nortel Ethernet Routing Switch 5510 front panels"](#) (page 34), ["Nortel Ethernet Routing Switch 5520 front panels"](#) (page 35), and ["Nortel Ethernet Routing Switch 5530-24TFD front panel"](#) (page 35) illustrate the LEDs and buttons found on the front panel of a switch in the 5500 Series Nortel Ethernet Routing Switch. Refer to the following sections for detailed explanations of the states indicated by each type of front panel LED:

- ["Switch LED state indicators"](#) (page 36)
- ["Port LED state indicators"](#) (page 38)
- ["Shared SFP transceiver port LED state indicators"](#) (page 39)
- ["XFP transceiver port LED indicators \(5530-24TFD only\)"](#) (page 39)

Note: For more information on the User Interface (UI) button and front panel configuration mode on the Nortel Ethernet Routing Switch 5500 Series, refer to the system configuration guide noted in ["Related publications"](#) (page 12).

Nortel Ethernet Routing Switch 5510 front panels



Nortel Ethernet Routing Switch 5510-24T

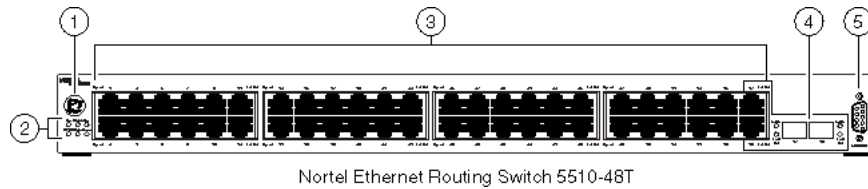

- | | |
|-------------------------------|------------------------------|
| 1. User Interface Button | 2. Switch LEDs |
| 3. 10/100/1000 Mbps Port LEDs | 4. SFP Transceiver Port LEDs |
| 5. Console Port | |

Nortel Ethernet Routing Switch 5520 front panels

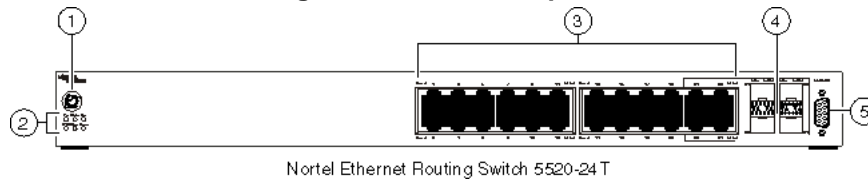

Nortel Ethernet Routing Switch 5520-24T

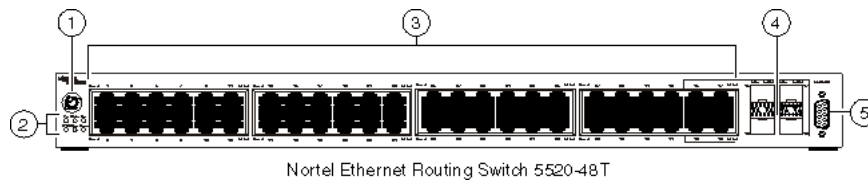

Nortel Ethernet Routing Switch 5520-48T

- | | |
|-------------------------------|------------------------------|
| 1. User Interface Button | 2. Switch LEDs |
| 3. 10/100/1000 Mbps Port LEDs | 4. SFP Transceiver Port LEDs |
| 5. Console Port | |

Nortel Ethernet Routing Switch 5530-24TFD front panel

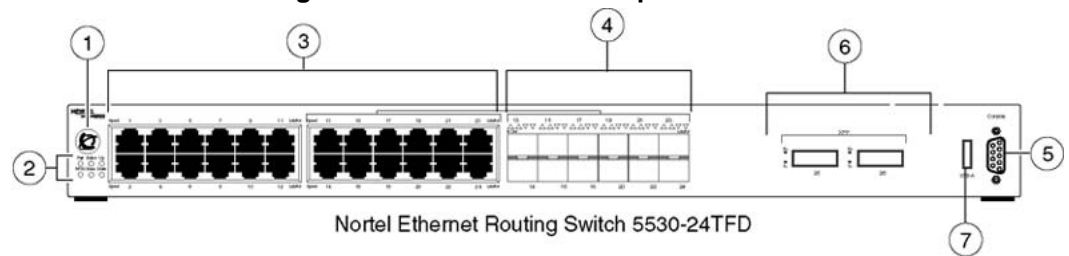

Nortel Ethernet Routing Switch 5530-24TFD

- | | |
|-------------------------------|------------------------------|
| 1. User Interface Button | 2. Switch LEDs |
| 3. 10/100/1000 Mbps port LEDs | 4. SFP Transceiver Port LEDs |
| 5. Console Port | 6. XFP Transceiver Port LEDs |
| 7. USB Port | |

Note: Copper ports 13 to 24 and the SFPs are shared ports on the Nortel Ethernet Routing Switch 5530-24TFD.



WARNING

Fiber optic equipment can emit laser or infrared light that can injure eyes. Never look into an optical fiber or connector port. Always assume that fiber optic cables are connected to a light source. For a translation of this statement, see "[Translations of safety messages](#)" (page 61).

Switch LED state indicators

"[Switch LED state indicators](#)" (page 36) outlines the different state indications that the main switch LEDs display through color and fluctuation cues.

Switch LED state indicators

Label	Color / Status	Description
UI button	White/steady	Power is on.
	Off	Power is off.
Pwr	Green / steady	The switch is connected to AC power and is receiving power.
	Green / blinking	Problem with primary Boot image. Booted from back up image. Configuration and agent code may be incorrect.
	Amber / slow blinking	System will reset in less than 3 seconds. To stop the reset, release UI push button.
	Amber / fast blinking	System will reset in less than 1 second. To stop the reset, release UI push button.
	Off	The switch is not connected to an AC power source or the power supply unit is not supplying power.
Status	Green / steady	<ul style="list-style-type: none"> During Initialization: The power-on self-test is complete and the switch is operating normally. After Initialization: The front panel configuration mode is inactive. Unit booted successfully.
	Green / blinking	<ul style="list-style-type: none"> During Initialization: A non-fatal error occurred during the self-test.

Label	Color / Status	Description
		<ul style="list-style-type: none"> • After Initialization: The user pushed the UI button and activated the front panel configuration mode and the system is awaiting input.
	Amber / steady	<ul style="list-style-type: none"> • During Initialization: N/A • After Initialization: The front panel has accepted the user command. The system accepts the UI input and is awaiting execution.
	Amber / blinking	<ul style="list-style-type: none"> • During Initialization: N/A • After Initialization: The system has rejected the UI input.
	Off	The switch failed the self-test.
RPSU	Green / steady	The switch is connected to a redundant power supply unit (RPSU) and is receiving power if necessary.
	Off	The switch is not connected to a RPSU, the RPSU is not supplying power, or the DC/DC module is not supplying power.
Up	Green / steady	The Cascade Up port has a physical connection to another unit.
	Amber / steady	The Cascade Up port has detected an error.
	Off	The switch is in standalone mode or there is no link to the Cascade Up port.
Down	Green / steady	The Cascade Down port has a physical connection to another unit.
	Amber / steady	The Cascade Down port has detected an error.
	Off	The switch is in standalone mode or there is no link to the Cascade Down port.
Base	Green / steady	The switch is the stack base unit.
	Green / blinking	There is a stack configuration error. Either multiple base units or no base units are configured in the stack.
	Amber / steady	The switch is operating as the temporary base unit in the stack configuration.
	Off	The switch is not the stack base unit or it is operating in standalone mode.

Port LED state indicators

This section outlines the state indicators provided by the port LED through color and fluctuation cues. Refer to the appropriate switch section for further information:

- "Nortel Ethernet Routing Switch 5510 and 5530" (page 38)
- "Nortel Ethernet Routing Switch 5520-24T-PWR or 5520-48T-PWR" (page 38)

Nortel Ethernet Routing Switch 5510 and 5530

Port LED state indicators for 5510 and 5530 Switches

Label	Color / Status	Description
Speed	Green / steady	The port is set to operate at 1000 Mbps.
	Amber / steady	This port is set to operate at 100 Mbps
	Off	When the LNK/ACT LED is green, this port is set to operate at 10 Mbps. When this LED is off, refer to the LNK/ACT section for more information.
LNK/ACT	Green / steady	The link is operating normally.
	Green / blinking	There is activity on the port. The blinking rate indicates the level of activity.
	Green / slow blinking	The port has been disabled by the software.
	Off	The port has no link nor activity.

Nortel Ethernet Routing Switch 5520-24T-PWR or 5520-48T-PWR

Port LED state indicators for 5520 Switches

Label	Color / Status	Description
Speed	Amber / steady	100 Mbps - PoE is off
	Amber / pulsing	100 Mbps - PoE is on
	Green / Amber Alternating	10 Mbps or No link or Admin disabled or PoE is on. Refer to the speed setting configured for this port to determine the specific state.
	Green / steady	1000 Mbps - PoE is off
	Green / pulsing	1000 Mbps - PoE is on
	Off	10 Mbps or No link or Admin disabled or PoE is off. Refer to the speed setting configured for this port to determine the specific state.

Label	Color / Status	Description
LNK/ACT	Amber / steady	PoE DTE short or the power allocated to this port has been exceeded.
	Amber / blinking	Power budget exceeded.
	Green / steady	Link established but no data activity.
	Green / blinking	There is activity on this port. The blinking rate indicates the level of activity.
	Off	No link.

Shared SFP transceiver port LED state indicators

This section outlines the states indicated by the color and fluctuation cues provided by the Shared SFP Transceiver Port LEDs.

Shared SFP transceiver Port LED state indicators

Label	Color / Status	Description
In Use	Green / steady	The port has a link established.
	Off	The port does not have a link established.
LNK/ACT	Green / steady	This link is operating normally.
	Green / blinking	There is activity on the port.
	Green / slow blinking	The port has been disabled by the software.
	Off	Indicates that the link has been lost.

Note: The SFP Transceiver ports are shared. When an SFP Transceiver is inserted and the port has a link established, the corresponding front panel port is disabled. For more information on shared ports, refer to the system configuration guide noted in ["Related publications" \(page 12\)](#).

XFP transceiver port LED indicators (5530-24TFD only)

The Nortel Ethernet Routing Switch 5530-24TFD contains two XFP Transceiver Ports with two LEDs labeled Tx (Transmit) and Rx (Receive). ["XFP transceiver port LED state indicators" \(page 40\)](#) outlines the port states indicated by the color and fluctuation of the XFP Transceiver Port LEDs.

XFP transceiver port LED state indicators

LED Color / Status	Description
Tx Green / steady	Link established.
Rx Green / steady	
Tx Green / blinking	Transmit activity detected.
Rx Green / blinking	Receive activity detected.
Tx Amber / steady	Transmit activity enabled.
Rx Amber / steady	Fiber connected with signal present.
Tx Amber / blinking	XFP has been installed. Laser Transmitter OFF or XFP in Reset.
Rx Amber / blinking	XFP has been installed. No Signal Detected or XFP in Reset.
Both Off	No XFP installed.
The Amber LEDs are usually only used during the boot process. Under normal operation, Green is the only color the XFP LED should emit.	

Setting IP parameters for the Nortel Ethernet Routing Switch 5500 Series

A 5500 Series Nortel Ethernet Routing Switch begins switching operations after it has completely booted up and all software modules are initialized. To manage the switch using Telnet or SNMP, or to perform TFTP operations, certain IP parameters must be set. In addition, if the switch is being connected into a stack configuration, the additional parameters necessary for the proper stack operation must be supplied.

For more information on the console menus, and configuring the switch, refer to the system configuration guide noted in "[Related publications](#)" (page 12).

For the initial set up of a switch, the following IP parameters must be configured:

- IP address of the switch or stack
- Subnet mask
- Gateway address

The following procedures are covered for setting initial IP Parameters:

- "[Setting IP parameters using the console port and Console Menu](#)" (page 41)
- "[Setting IP Parameters using the console port and CLI](#)" (page 44)

- "Setting IP parameters using the Web-based Management Interface" (page 47)
- "Setting IP parameters using the UI button" (page 48)

Setting IP parameters using the console port and Console Menu

To set IP parameters using the console port and Console Menu, perform the following tasks:

Step	Action
------	--------

- | | |
|---|---|
| 1 | <p>Connect a terminal to the console port of the switch.</p> <p>Any terminal or PC with an appropriate terminal emulator can be used as the management station. " Terminal emulation settings" (page 41) lists the parameters that must be used with any terminal emulation software used to connect to the switch.</p> |
|---|---|

Terminal emulation settings

Property	Value
Baud Rate	9600 bps
Data Bits	8
Stop Bits	1
Parity	None
Flow Control	None

A console cable and connector to match the male DTE connector (DB-9) on the switch is required to connect the terminal to the switch console port.

- | | |
|---|--|
| 2 | Set the terminal protocol on the terminal or terminal emulation program to VT100 and VT100/ANSI. |
| 3 | Connect to the switch using the terminal or terminal emulation application. |
| 4 | After the Nortel banner is displayed, press CTRL + Y to display the main menu. The version of the main menu displayed is dependent on whether the switch is part of a standalone or stacked switch configuration. " Standalone switch main menu " (page 42) illustrates the main menu for a standalone configuration and " Stacked switch main menu " (page 42) illustrates the main menu for a stacked switch configuration. |

Standalone switch main menu

```
IP Configuration/Setup...
SNMP Configuration...
System Characteristics...
Switch Configuration...
Console/Comm Port Configuration...
Display Hardware Units...
Spanning Tree Configuration...
TELNET/SNMP/Web Access Configuration...
Software Download...
Configuration File...
Display System Log...
Reset...
Reset to Default Settings...
Shutdown Command...
Command Line Interface...
Logout...
```

Use arrow keys to highlight option, press <Return> or <Enter> to select option.

Stacked switch main menu

```
IP Configuration/Setup...
SNMP Configuration...
System Characteristics...
Switch Configuration...
Console/Comm Port Configuration...
Identify Unit Numbers...
ReNUMBER Stack Units...
Display Hardware Units...
Spanning Tree Configuration...
TELNET/SNMP/Web Access Configuration...
Software Download...
Configuration File...
Display System Log...
Reset...
Reset to Default Settings...
Shutdown Command...
Command Line Interface...
Logout...
```

Use arrow keys to highlight option, press <Return> or <Enter> to select option.

5 Select **IP Configuration/Setup . . .** from the main menu.

Note: The default management VLAN in the Nortel Ethernet Routing Switch 5500 Series is VLAN 1. To manage the switch, ensure that the network management station is on the management VLAN or is connected to the management

VLAN through routers. For information on the maintenance and configuration of VLANs, refer to the system configuration guide noted in "[Related publications](#)" (page 12).

- 6 Assign an IP address to the switch.
 - For a standalone switch, enter a value in the **In-Band Switch IP Address** field in dotted-decimal notation.
 - For a stack configuration, enter a value in the **In-Band Stack IP Address** field in dotted-decimal notation.

IP Configuration/Setup screen

```

IP Configuration/Setup
BootP Request Mode: [ BootP When Needed ]

Configurable   In Use   Last BootP
-----
In-Band Stack IP Address: [ 0.0.0.0 ] 0.0.0.0 0.0.0.0
In-Band Switch IP Address: [ 0.0.0.0 ] 0.0.0.0 0.0.0.0
In-Band Subnet Mask: [ 0.0.0.0 ] 0.0.0.0 0.0.0.0
Default Gateway: [ 0.0.0.0 ] 0.0.0.0 0.0.0.0
IP Address to Ping: [ 0.0.0.0 ]
Start Ping: [ No ]
Enter text, press <Return> or <Enter> when complete.
Press Ctrl-R to return to previous menu. Press Ctrl-C
to return to Main Menu.

```

Note: The **In-Band Switch IP Address** field allows a switch to operate as a standalone switch. This field is not required for the operation of a stacked switch. The same value cannot be entered in both the **In-Band Switch IP Address** field and the **In-Band Stack IP Address** field.

- 7 In the **In-Band Subnet Mask** field enter the appropriate subnet mask in dotted-decimal notation.

Note: If the **In-Band Subnet Mask** field does not already contain a value when specifying an IP address for the switch, the switch software provides an in-use, default value for the subnet mask field. This value is based on the class of the IP address entered in the previous step.
- 8 In the Default Gateway field, enter the appropriate default gateway in dotted-decimal notation.

Note: If Nortel Ethernet Routing Switch 5500 Series switches are being stacked, ensure that one switch is set as the Base Unit. For more information on this topic, refer to system configuration guide noted in "[Related publications](#)" (page 12).

- 9 Press CTRL + C to return to the main menu.
- 10 Initial IP configuration is now complete. To continue with configuration operations, select the appropriate menu item. To disconnect from the switch select **Logout** from the main menu.

—End—

Setting IP Parameters using the console port and CLI

To set IP parameters using the console port and Command Line Interface, perform the following tasks:

Step	Action
------	--------

- | | |
|---|--|
| 1 | <p>Connect a terminal to the console port of the switch.</p> <p>Any terminal or PC with an appropriate terminal emulator can be used as the management station. "Terminal emulation settings" (page 41) lists the parameters that must be used with any terminal emulation software used to connect to the switch.</p> |
|---|--|

Terminal emulation settings

Property	Value
Baud Rate	9600 bps
Data Bits	8
Stop Bits	1
Parity	None
Flow Control	None

A console cable and connector to match the male DTE connector (DB-9) on the switch is required to connect the terminal to the switch console port.

- 2 Set the terminal protocol on the terminal or terminal emulation program to VT100 and VT100/ANSI.
- 3 Connect to the switch using the terminal or terminal emulation application.

- 4 After the Nortel banner is displayed, press **CTRL + Y** to display the main menu. The version of the main menu displayed is dependent on whether the switch is part of a standalone or stacked switch configuration. "Standalone switch main menu" (page 42) illustrates the main menu for a standalone configuration and "Stacked switch main menu" (page 42) illustrates the main menu for a stacked switch configuration.

Standalone switch main menu

```
IP Configuration/Setup...
SNMP Configuration...
System Characteristics...
Switch Configuration...
Console/Comm Port Configuration...
Display Hardware Units...
Spanning Tree Configuration...
TELNET/SNMP/Web Access Configuration...
Software Download...
Configuration File...
Display System Log...
Reset...
Reset to Default Settings...
Shutdown Command...
Command Line Interface...
Logout...
```

Use arrow keys to highlight option, press <Return> or <Enter> to select option.

Stacked switch main menu

```
IP Configuration/Setup...
SNMP Configuration...
System Characteristics...
Switch Configuration...
Console/Comm Port Configuration...
Identify Unit Numbers...
Rename Stack Units...
Display Hardware Units...
Spanning Tree Configuration...
TELNET/SNMP/Web Access Configuration...
Software Download...
Configuration File...
Display System Log...
Reset...
Reset to Default Settings...
Shutdown Command...
Command Line Interface...
```

Logout...

Use arrow keys to highlight option, press <Return> or <Enter> to select option.

- 5 Select **Command Line Interface**. . .from the main menu.

Note: The default management VLAN in the Nortel Ethernet Routing Switch 5500 Series is VLAN 1. To manage the switch, ensure that the network management station is on the management VLAN or is connected to the management VLAN through routers. For information on the maintenance and configuration of VLANs, refer to the system configuration guide noted in "[Related publications](#)" (page 12).

- 6 Enter the Global Configuration command mode using the **enable** and **configure terminal** commands. This is illustrated below.

Entering Global Configuration mode

```
5530-24TFD#enable
5530-24TFD#configure terminal
Enter configuration commands, one per line.
End with CNTL/Z.
5530-24TFD(config)#
```

- 7 In the Global Configuration command mode use the **ip address** command to set the switch or stack IP address. The syntax of this command is outlined below.
- ip address [stack | switch] <ip_address> [netmask <subnet_mask>] [default-gateway <gateway_address>]**
- The parameters of this command are outlined in the following table.

ip address parameters

Parameter	Description
[stack switch]	Use either the stack or switch key word to set the appropriate IP address.
<ip_address>	The IP address to be used.
<subnet_mask>	The subnet mask to be used.
<gateway_address>	The default gateway address to be used.

- 8 Initial IP configuration is now complete. To continue with configuration operations, use the appropriate CLI commands. To disconnect from the switch use the **logout** command to return to the Console Menu and select **Logout** from the main menu.

—End—

Setting IP parameters using the Web-based Management Interface

Note: IP parameters are changed during this procedure. Changes to IP parameters can result in the loss of web browser connectivity to the switch.

To set IP parameters using the Web-based Management Interface, perform the following tasks:

- | Step | Action |
|------|---|
| 1 | Using the procedure " Setting IP parameters using the UI button " (page 48), assign a default IP address to the switch. |
| 2 | Connect a computer to the switch through a data port using a standard RJ-45 network cable. |
| 3 | Open a web browser on the attached computer and enter the factory default IP address of the switch in the following format: <i>http://<IP Address></i> . |
| 4 | The main screen of the Web-based Management Interface will open. Select Configuration > IP from the menu. This screen is illustrated below. |

IP configuration screen

Configuration > IP

IP Setting			
	Configurable	In Use	Last BootP
In-Band Stack IP Address	0.0.0.0	0.0.0.0	0.0.0.0
In-Band Switch IP Address	192.168.192.168	192.168.192.168	0.0.0.0
In-Band Subnet Mask	255.255.255.0	255.255.255.0	0.0.0.0
Default Gateway	0.0.0.0	0.0.0.0	0.0.0.0

Submit

- 5 Using the fields provided, configure the IP parameters. All fields are divided into three columns: **Configurable**, **In Use**, and **Last BootP**. The **Configurable** column is used to configure a new value for the field. The **In Use** column represents the current value used by the switch and the **Last BootP** column is used to display a value

assigned to the field by a BootP request. These fields are outlined in the following table.

IP Configuration fields

Field	Description
In-Band Stack IP Address	The IP address used by the switch when it is part of a stack.
In-Band Switch IP Address	The IP address used by the switch when it is a standalone unit.
In-Band Subnet Mask	The subnet mask used by the switch.
Default Gateway	The default gateway used by the switch.

6 Click **Apply**.

—End—

Setting IP parameters using the UI button

IP parameters can also be set by using the front panel User Interface (UI) button. This allows for switch configuration without the need for a Console connection.

Depending on the state of the switch, applying IP parameters in this manner will result in either the parameters being applied to the switch itself or to a switch stack. When the unit is in a stack, the UI button on any unit of the stack can be used to set the IP parameters. Ensure however that performing this procedure does not result in duplicate IP addresses on the network. If the default IP configuration is set, any change to the configured IP address or subnet mask through the other user interfaces will cause the In-Use IP configuration of the switch or stack to change. Therefore, the newly configured IP address must be used to manage the switch or stack. If the unit is being reset using the UI button, wait for 60 seconds after the last configuration change. The system takes up to 60 seconds to save the configuration changes to NVRAM.

The stack can be reset immediately after changing the configuration by using the UI button without losing any of the changed configuration.

Note 1: The UI button may be used at any time to change the In-Use IP address and subnet mask of the switch. It overrides the current In-Use IP address and subnet mask, if any, regardless of the BootP mode settings for the switch or stack.

Note 2: If there is a change in the switch state, that is, if it joins or leaves a stack after the default IP configuration is set, the In-Use IP configuration will change, and must be set again using the UI button.

It should be noted that configuring IP parameters in this manner does not have the same amount of control as configuration using a Console connection. Using this procedure will set the IP address to a pre-configured default of *192.168.192.168*.

To set IP parameters using the UI button, perform the following tasks:

Step	Action
1	<p>Press and hold the UI button for 3 seconds.</p> <p>The unit will now be in configuration mode. The Status LED will now change to a blinking green status.</p>
2	<p>Press the UI button 5 times.</p> <p>The Base LED and the Up and Down LEDs will now be steady amber to indicate that the button press was recognized.</p>
3	<p>Press the UI button and hold in for 3 seconds to confirm the command.</p> <p>The In-Use IP address will now be changed to <i>192.168.192.168</i>. The color and status of the Status LED will turn to steady green once the command has been accepted. If the command is rejected, the Status LED turns amber blinking.</p>
4	<p>Initial IP configuration using the UI button is now complete. To continue with switch configuration access the switch through the Command Line Interface, Web-based Management Interface, or Java Device Manager.</p>

—End—

Nortel Ethernet Routing Switch 5500 Series Stack Configuration

The Nortel Ethernet Routing Switch 5500 Series provides the capability for fail-safe stackability. Up to eight 5500 Series devices can be connected in a stack to provide uninterrupted connectivity for up to 384 ports. This stack is managed as a single unit.

Stack connector

The stack connector is a component of the Nortel Ethernet Routing Switch 5500 Series back panel and consists of the Unit Select switch, Cascade Down connector, and Cascade Up connector. The stack connector is illustrated in the following diagram.

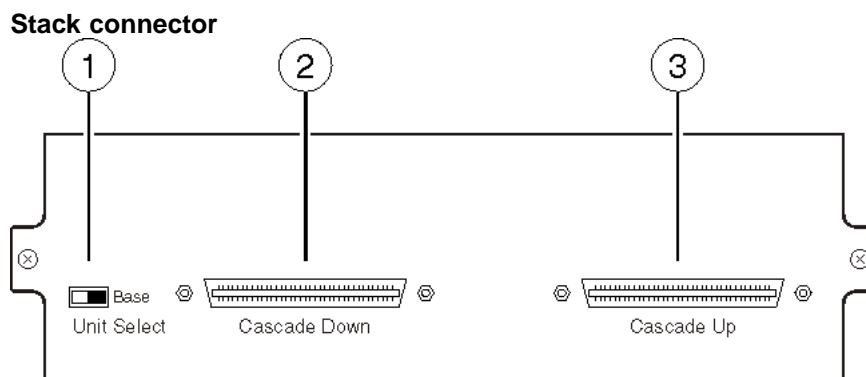

- 1 = Unit select switch
- 2 = Cascade down connector
- 3 = Cascade up connector

Unit Select switch

The Unit Select switch is used to designate a switch in the stack as the *base unit*. Sliding the switch to the right designates that switch as the base unit. Only one switch in a stack may have the Unit Select switch in the base unit position. All other switches in the stack must have the Unit Select switch in the left position.

A switch's base unit designation is also displayed on the front panel LED display.

Cascade Down connector

The Cascade Down connector is used to connect this switch to the next unit in the stack through a cascade cable. A connection from this connector must be attached to the Cascade Up connector of the next switch in the stack. A return cable from another unit's Cascade Down connector to this unit's Cascade Up connector completes the stack connection.

Note: To create a stack connection, order the appropriate Nortel Ethernet Routing Switch 5500 Series cascade cables to ensure fail-safe stacking. These cables are not provided with the switch. For stacking three or more units (maximum 8 units per stack), order the 3 foot cascade max-return cable (order number AL2018009).

Cascade Up connector

The Cascade Up connector provides an attachment point for accepting a cascade cable connection from another unit in the stack. A return cable from this unit's Cascade Down connector to the adjacent unit's Cascade Up connector completes the stack connection.

Note: To create a stack connection, order the appropriate Nortel Ethernet Routing Switch 5500 Series cascade cables to ensure fail-safe stacking. These cables are not provided with the switch.

The following illustration demonstrates the proper crossover connection configuration. Failure to use this configuration can result in loss of connectivity.

Connecting cascade cables

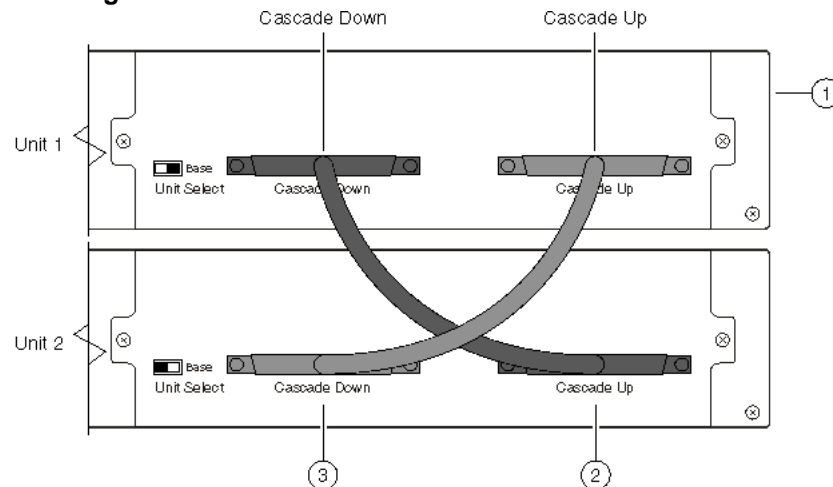

1. Base Unit
2. Cascade Cable
3. Cascade Cable (used for return)

Stack configuration

Switches in a stack must be configured to perform as either the base or non-base units in the stack. The base unit performs important tasks during stack functioning and it is important that only one switch be designated as base.

These stack configuration tasks can be performed using either the User Interface (UI) button on the front panel of the switch or the Unit Select switch on the back. The following sections describe the procedures for performing these tasks.

Stack configuration using the UI button

The UI button can be used to perform a number of stack configuration tasks. This section describes the following tasks:

- ["Setting the Base Unit" \(page 52\)](#)
- ["Setting the Non-Base Units" \(page 52\)](#)

- "Resetting the stack" (page 53)
- "Abandoning a command" (page 53)

Setting the Base Unit To set the stack base unit with the UI button, follow this procedure:

Step	Action
1	Press and hold the UI button for three seconds. The unit is now in configuration mode. The color and status of the Status LED turns to blinking green.
2	Press the UI button once. The Base LED is illuminated and the Up and Down LEDs are steady green to indicate that the button press was recognized.
3	Press and hold the UI button for three seconds to confirm the command. The Status LED returns to a steady green state to confirm command acceptance. If the command is rejected, the Status LED moves to a blinking amber state.

—End—

Note: The switch does not become the base unit until the next time the switch is restarted.

Setting the Non-Base Units To set the stack non-base units with the UI button, follow this procedure:

Step	Action
1	Press and hold the UI button for three seconds. The unit is now in configuration mode. The color and status of the Status LED turns to blinking green.
2	Press the UI button twice. The Base LED will turn off and the Up and Down LEDs will move to a steady green state.
3	Press and hold the UI button for three seconds to confirm the commands.

The Status LED returns to a steady green state to confirm command acceptance. If the command is rejected, the Status LED moves to a blinking amber state.

—End—

Note: The switch does not become the non-base unit until the next time the switch is restarted.

Resetting the stack To reset the stack using the UI button, follow this procedure:

Step	Action
------	--------

- | | |
|---|---|
| 1 | Press and hold the UI button for three seconds.
The unit is now in configuration mode. The color and status of the Status LED turns to blinking green. |
| 2 | Press the UI button three times.
The Base, Up, and Down LEDs will move to a blinking amber state and blink in unison. |
| 3 | Press and hold the UI button for three seconds to confirm the command. |
-

—End—

Abandoning a command Once a command entered through the UI button is accepted, the new configuration is stored in NVRAM. To abort a command entered using the UI button, perform one of the following actions:

- Wait approximately twenty seconds after entering the command (without confirming it) and the input is ignored.
- Exit configuration mode by pressing the UI button five or more times.

Note: Wait sixty seconds after the last configuration change before resetting the unit. The system can take up to this long to save configuration changes to the NVRAM. Stacks can be reset immediately after the last configuration change without any loss of information.

Stack configuration using the Unit Select switch

The Unit Select switch is used to designate a switch in the stack as a base or non-base unit. Sliding the switch to the right designates that switch as the base unit. Only one switch in a stack may have the Unit Select switch in the base unit position. All other switches in the stack must have the Unit Select switch in the left position which designates them as non-base units.

Initial installation

During the initial installation of the stack, the software automatically determines the physical order of all units in the stack according to the position of the base unit within the stack. Thereafter, the individual units maintain their original unit numbering, even if the position of one or more units in the stack is changed.

For example, when the stack is initially powered, the base unit becomes unit 1 and the unit that the base unit connects to (via the Cascade Down cable) becomes unit 2 (and the next unit is unit 3 and so on), until the maximum stack configuration (up to 8 units) is reached. If the base unit is changed to another unit in the stack, the new base unit keeps its original unit number in the stack.

Stack MAC address

When a switch participates in a stack configuration, a stack MAC address is automatically assigned during stack initialization. The stack MAC address is the base unit MAC address plus 1. If another unit in the stack is assigned as the base unit, the new stack MAC address is the MAC address of the new base unit plus 1. The original stack IP address still applies to the new base unit.

Temporary base unit

If an assigned base unit fails, the next unit in the stack order automatically becomes the new temporary base unit. This change is indicated by the Base LED on the temporary base unit LED display panel moving to a steady amber state.

This automatic failover is a temporary safeguard only. If the stack configuration loses power, the temporary base unit will not power up as the base unit when power is restored. Also, if the original unit rejoins the stack, it will not resume base unit status. For this reason, always assign the temporary base unit as the base unit until the failed unit is repaired or replaced.

Note: If the temporary base unit is not assigned as the new base unit, and the temporary base unit fails, the next unit in the stack order becomes the temporary base unit. This process will continue after successive failures until only two units are left in the stack.

Removing a stack unit

If a unit is removed from the stack (therefore operating in standalone mode), the following switch configuration settings revert to those configured before the unit became a member of the stack:

- IP address
- Console, Web, Telnet, and SNMP passwords
- SNMP community strings

Replacing a stack unit

Note: Use only the console interface, command line interface, or Web-based management system to replace or insert units in the stack.

To replace a failed stack unit or insert a new unit into a stack, follow this procedure:

Step	Action
1	<p>Upload a copy of the stack configuration file to a TFTP server.</p> <p>Since unit failure is not a predictable situation, it is suggested that the stack configuration file is backed up regularly to a TFTP server.</p> <p>Note: The stack configuration file must be in binary form.</p>
2	<p>Obtain the new switch.</p> <p>Ensure that the new switch is set to factory default values. This new unit will be configured in standalone mode before inserting it into the stack.</p>
3	<p>Download the configuration file to the new unit.</p> <p>Download the stack configuration file produced in step 1. The new unit will extract the relevant configuration information.</p>
4	<p>Set the unit number.</p> <p>After the configuration file has been downloaded to the new unit, specify the stack unit that this new unit will replace. The switch will reboot with the stack configuration information.</p>
5	<p>Physically insert the new unit.</p> <p>Turn off the new unit and physically replace the failed unit in the stack. Complete the cabling to attach the new unit to the stack and turn on the new unit.</p>
<hr/> <p>—End—</p> <hr/>	

If the base unit is being replaced, remember that the stack will have elected a temporary base unit. The new unit will not automatically assume the base unit status. Configure the new unit as the base unit using either the Unit Select switch or UI button and reset the stack to make the new unit the base unit.

For a more detailed explanation of this procedure, including an explanation of the Auto Unit Replacement (AUR) feature, see *Ethernet Routing Switch 5500 Series Configuration — System (NN47200-500)*.

Stack configurations

Due to stack parameters being associated with the base unit, the physical stack order depends on the base unit position and whether the stack is configured *cascade up (stack up)* or *cascade down (stack down)*. This designation depends on the stack cabling arrangement.

The system automatically numbers the physical units based on the designated base unit (Unit 1). In a cascade down configuration, the base unit is physically located as the top unit in the stack. The cable connected to the Cascade Down connector of the base unit terminates in the Cascade Up connector on the next unit in the stack which is physically located below the base unit. This next unit is designated Unit 2. The stack is wired downward through the units and the system continues to number in this manner throughout the stack. In this configuration, the base unit discovers the stack in a cascade down (stack down) direction. The following illustration demonstrates a cascade down (stack down) configuration.

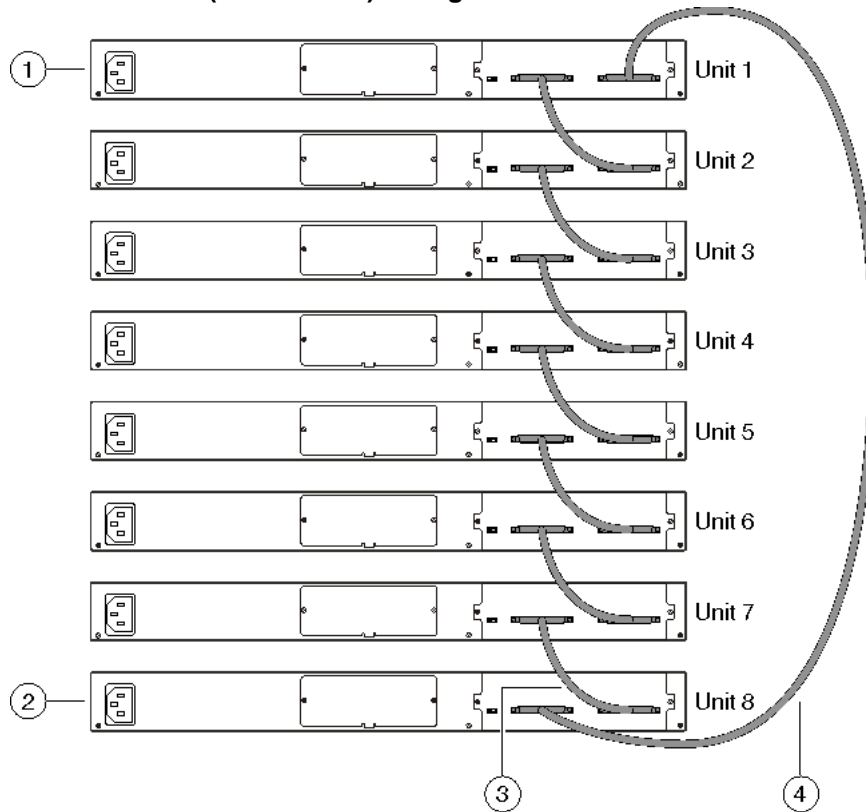
Cascade Down (Stack Down) configuration

1. Base Unit
2. Last Unit
3. Cascade Cable
4. Cascade Cable

In a cascade up (stack up) configuration, the base unit is physically located as the top unit in the stack. The cable connected to the Cascade Down connector of the base unit terminates in the Cascade Up connector physically located at the *bottom* of the stack. This next unit is designated Unit 2. The stack is wired upward through the units and the system continues to number in this manner throughout the stack. In this configuration, the base unit discovers the stack in a cascade up (stack up) direction. The following illustration demonstrates a cascade up (stack up) configuration.

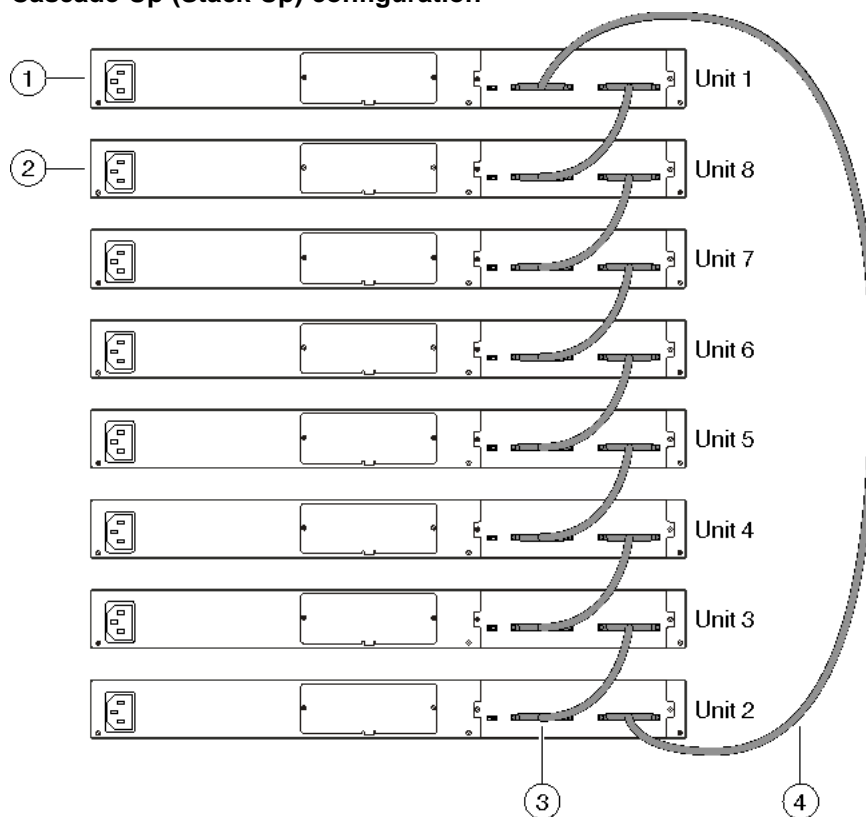
Cascade Up (Stack Up) configuration

1. Base Unit
2. Last Unit
3. Cascade Cable
4. Cascade Cable

Note: Since many network management software packages assume a cascade down (stack down) configuration, Nortel recommends the usage of this configuration.

Regardless of stack configuration, the following applies:

- When power is applied to the stack the base unit initializes, typically within sixty seconds, and the entire stack powers up as a single logical unit.
- A RS-232 communications cable can be attached to the console port of any switch in the stack to establish a console connection.

- A software upgrade can be performed on the stack from any switch using the console interface, a Telnet session, the Web-based management interface, or any SNMP-based management software.
- The stack can be managed using a Telnet session, Web-based management interface, or any SNMP-based management software through any stack switch port.
- When stacking two or more switches. use the three foot cascade max-return cable (part number AL2018009) to complete the link from the last unit in the stack to the base unit.

Redundant cascade stacking

The Nortel Ethernet Routing Switch 5500 Series allows a stack of up to 8 units into a dual-path cascade stack. If any single unit fails or if a cable is accidentally disconnected, other units in the stack remain operational without interruption.

In addition to increasing bandwidth, the software uses the cables to provide two paths between units. If one path breaks the data travels over the remaining path with half the normal inter-switch bandwidth.

The following diagram shows an example of how a stack configuration reacts to a failed connection in the stack configuration. In the illustrated example, the following is occurring:

- Unit 3 becomes non-operational due to a unit failure, cable disconnection, or a loss of power.
- Units 2 and 4, directly upstream and downstream from Unit 3, sense the loss of link signals from unit 3. The software causes all the data to traverse the remaining path.
- The Cascade Down LED for Unit 2 and the Cascade Up LED for Unit 4 turn amber to indicate an error has been detected.
- The remaining stack units continue to be connected.

Redundant cascade stacking

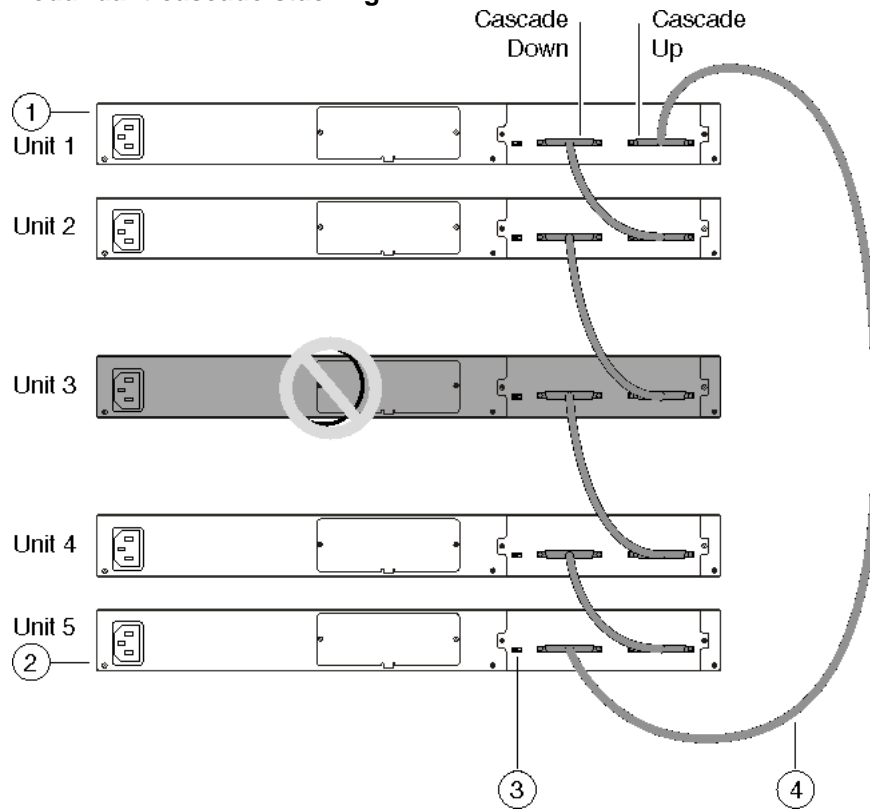

1. Base Unit
2. Last Unit
3. Cascade Cable
4. Cascade Cable

Translations of safety messages

**CAUTION**

When mounting this device in a rack, do not stack units directly on top of one another in the rack. Each unit must be secured to the rack with appropriate mounting brackets. Mounting brackets are not designed to support multiple units.

ATTENTION**Achtung:**

Wenn diese Einheit in einem Rack montiert wird, muß ein gewisser Abstand zur nächsten Einheit gelassen werden. Jede Einheit muß mit geeignetem Befestigungsmaterial gesichert werden. Das Befestigungsmaterial ist nicht für die gleichzeitige Befestigung mehrerer Einheiten geeignet.

ATTENTION

Si vous installez le module dans une baie, ne l'empilez pas directement sur un autre. Chaque module doit être fixé à sa propre baie à l'aide des supports de montage appropriés. Ces supports ne sont pas conçus pour résister à plusieurs modules.

ATTENTION**Precaución:**

Cuando monte este dispositivo en un bastidor, no apile las unidades directamente una encima de otra. Cada unidad debe fijarse en el bastidor con las abrazaderas de montaje adecuadas. Las abrazaderas de montaje no están diseñadas para sostener varias unidades.

ATTENTION

Se il dispositivo viene installato in un rack, non impilare le unità direttamente una sull'altra. Ogni unità deve essere fissata al rack con le staffe di montaggio appropriate. Le staffe di montaggio non sono state progettate per supportare più unità.



警告：在机架中安装此设备时，请勿将多个部件叠放在机架中。必须用合适的安装托架将各个部件固定在机架中。安装托架无法支撑多个部件。



注意：この装置をラックに設置する場合は、ラック内のユニットを直接積み重ねないようにしてください。各ユニットは専用の取り付けブラケットでラックに固定する必要があります。取り付けブラケットは複数のユニットを支えるようには設計されていません。



注意：在機箱中掛載此裝置時，請不要直接在機箱中的另一個裝置上直接堆放裝置。每一裝置都必須使用適當的掛載托架以固定在機架中。掛載托架不能用來支撐多個裝置。



CAUTION

If you are not installing a module in the slot, be sure to keep the metal cover plate in place over the slot. Removing the cover plate impedes airflow and proper cooling of the unit.

ATTENTION

Achtung:

Wenn Sie kein Modul im Schacht verwenden, muß die Metallabdeckung über dem Schacht montiert sein. Eine Entfernung der Abdeckung führt zu einer Verschlechterung der Luftzirkulation und damit zu einer nicht ausreichenden Kühlung der Einheit.

ATTENTION

Si vous n'installez pas le module dans une baie, veillez à laisser la plaque métallique sur la baie. Si vous la retirez, l'aération du module ne peut pas s'effectuer correctement.

ATTENTION

Precaution:

Si no instala ningún módulo en la ranura, asegúrese de mantener la placa de la cubierta de metal en la misma. Si la retira, impedirá que el aire circule y la unidad se refrigere adecuadamente.

ATTENTION**Attenzione:**

Se nello slot non vengono installati moduli, assicurarsi di mantenere la piastra di copertura metallica in sede sopra lo slot. La rimozione della piastra impedisce la ventilazione e il corretto raffreddamento dell'unità.



注意: この装置をラックに設置する場合は、ラック内のユニットを直接積み重ねないようにしてください。各ユニットは専用の取り付けブラケットでラックに固定する必要があります。取り付けブラケットは複数のユニットを支えるようには設計されていません。



注意: スロットにモジュールを取り付けない場合は、スロットにある金属製のカバープレートが外れないように注意してください。カバープレートを動かすと気流が妨げられ、適切なユニット冷却が行われなくなります。



注意: 如果您未在插槽中安裝模組，請確定金屬殼板正確地蓋在插槽上。移除殼板會阻礙空氣流通以及裝置的適當冷卻度。



警告: 如果您不打算在该插槽中安装任何模块，请务必使金属盖板正确地盖住该插槽。如果取下盖板，将妨碍通风及部件散热。



警告: この装置の電源は、電源コードを抜かない限り切断できません。緊急の場合にすばやく安全に切断できる場所に電源コードを接続してください。



警告: 若要關閉此裝置的電源，拔掉插頭是唯一的方法。為了因應緊急狀況，請將電源線連接到可以快速插拔的地方。

**WARNING**

Disconnecting the AC power cord is the only way to turn off AC power to this device. Always connect the AC power cord in a location that can be reached quickly and safely in case of an emergency.

ATTENTION

Warnung:

Das Gerät kann nur durch Ziehen des Netzsteckers ausgeschaltet werden. Schließen Sie das Netzkabel an einer Steckdose an, die in Notfällen schnell und sicher zugänglich ist.

ATTENTION

Avertissement:

Pour mettre le module hors tension, vous devez impérativement déconnecter le cordon d'alimentation. En outre, vous devez dégager un espace minimal dans la zone de câblage pour pouvoir y accéder facilement en cas d'urgence.



警告： 断开交流电源线是切断本设备的交流电源的唯一方法。交流电源线一定要连接到在紧急时刻可以快速安全地接触到的位置。

ATTENTION

Advertencia:

Para apagar el dispositivo debe desenchufar el cable. Conecte siempre el cable de alimentación a una toma segura y de fácil acceso por si se produjera alguna situación de emergencia.

ATTENTION

Avviso:

L'unico modo per disattivare questo dispositivo consiste nello scollegare il cavo di alimentazione. Collegare sempre il cavo di alimentazione ad una presa che sia facilmente e rapidamente accessibile in caso di emergenza.



DANGER

Use only power cords that have a grounding path. Without a proper ground, a person who touches the switch is in danger of receiving an electrical shock. Lack of a grounding path to the switch may result in excessive emissions.

ATTENTION

Vorsicht:

Verwenden Sie nur Netzkabel mit Schutzerdung. Ohne ordnungsgemäße Schutzerdung besteht für Personen, die den Switch berühren, die Gefahr eines elektrischen Schlages. Eine nichtvorhandene Schutzerdung kann zu sehr starken Abstrahlungen führen.

**DANGER**

N'utilisez que des cordons d'alimentation équipés de trajet de mise à la terre. Sans mise à la terre adaptée, vous risquez de recevoir une décharge électrique en touchant le commutateur. Par ailleurs, l'absence de trajet de mise à la terre peut générer des émissions excessives.

ATTENTION**Peligro:**

Utilice únicamente cables de alimentación con toma de tierra. De lo contrario, al tocar el interruptor puede recibir una descarga eléctrica. Si no hay un circuito de toma de tierra en el enchufe, puede producirse un exceso de emisiones.

ATTENTION**Pericolo:**

Utilizzare esclusivamente cavi di alimentazione dotati di un percorso per la messa a terra. Senza un'adeguata messa a terra, chiunque tocchi lo switch corre il rischio di ricevere una scossa elettrica. L'assenza di un percorso per la messa a terra verso lo switch può comportare un eccesso di emissioni.



危険: 接地経路を持つ電源コードを必ず使用するようになしてください。適切な接地がない状態でスイッチに触ると、感電する危険性があります。また、スイッチへの接地経路がないと、過度な放電を引き起こす可能性があります。



危险: 请仅使用接地的电源线。如果电源线不接地或接地不当, 接触交换机的人员可能会受到电击。如果交换机不接地, 则可能导致放电过量。

Index

Symbols/Numerics

5530-24TFD USB ports 29

A

Accessing technical assistance 13

C

Cable requirements 24

Connecting AC power 32

Console pin assignments 29

D

Documentation updates 13

E

Electrostatic discharge 16

Environmental requirements 17

ESD 16

I

Initial IP parameters 40

Installing the Nortel Ethernet Routing
Switch 15

P

Package contents 19

Phone dongle 16

Power specifications 30

Preface 11

R

Rack installation 21

Rear mounted installation 23

Related publications 12

RJ-45 pin assignments 27

S

Setting IP parameters 40

SFP installation 25

SFP removal 26

Shelf installation 20

Software updates 13

Stack configuration 49

Switch LEDs 34

Switch platforms

T

Table installation 20

Translations of safety messages 61

U

USB ports 29

X

XFP installation 25

XFP removal 26

Nortel Ethernet Routing Switch 5500 Series

Installation

Copyright © 2005 - 2008 , Nortel Networks
All Rights Reserved.

Publication: NN47200-300
Document status: Standard
Document version: 03.02
Document date: 16 December 2008

To provide feedback, or report a problem in this document, go to <http://www.nortel.com/documentfeedback>.

Sourced in Canada and the United States of America

The information in this document is subject to change without notice. Nortel Networks reserves the right to make changes in design or components as progress in engineering and manufacturing may warrant.

*Nortel, Nortel Networks, the Nortel logo, and the Globemark are trademarks of Nortel Networks.

