

BT Synergy 6500

# User Guide



Bringing it all together

This new interactive user guide lets you navigate easily through the pages and allows you to be directed straight to any websites or email addresses that are referenced.

Simply hover the cursor over the page number, website or email reference and click when the hand icon changes to the  icon.



Think before  
you print!

This User Guide provides you with all the information you need to get the most from your phone.

You must first set up your phone before you can use it. This doesn't take long as it is easy to do. Just follow the simple instructions on the next few pages.

### Need help?

If you have any problems setting up or using your BT Synergy 6500 please call our free Helpline on 0800 145 6789\* or email [bt.helpdesk@sgweurope.com](mailto:bt.helpdesk@sgweurope.com).

Our dedicated advisers are more likely to be able to help you than the retailer where you made your purchase.

Alternatively, you may find the answer in the 'Help' section at the back of this guide.

### Hearing aid?

Please note that the BT Synergy 6500 works by sending radio signals between the base and handset. These signals may interfere with some hearing aids, causing a humming noise.

### IMPORTANT

Only use the telephone line cord supplied.

### Got everything?

- BT Synergy 6500 base
- BT Synergy 6500 handset
- 2 x AAA NiMH 750mAh rechargeable batteries
- Mains power adaptor for the base (item code 040497)
- Telephone line cord (pre-installed)

### If you have purchased a BT Synergy 6500 multiple pack you will also have the following for each handset:

- BT Synergy handset & charger
- 2 x AAA NiMH 750mAh rechargeable batteries
- Mains power adaptor for charger (item code 032765)

\* Calls made from within the UK mainland network are free. Mobile and International call costs may vary.

# In this guide

## Getting started

Location	6
Setting up	6
Setting up for multiple packs	7
Date and time	8

## Getting to know your phone

Handset buttons	9
Standby screen	10
Display icons	10
Base	11
Navigating the menus	12
Menu map	13
Character map	14

## Using the phone

Switch the handset on / off	15
Make a call	15
Preparatory dialling	15
End a call	15
Receive a call	15
Adjust the earpiece/receiver volume	16
Secrecy	16
Make a handsfree call	16
Answer a call handsfree	16
Switch to handsfree during a call	16
Redial the last number called	16
Redial a number from the redial list	16

Save a number from the redial list to the phonebook	17
Delete a redial number/delete all redial	17
To lock/unlock the keypad	17
Paging/Find handset	17
250 Name and number phonebook	18
Store a name and number in the phonebook	18
Store an entry from the phonebook to a speed dial button	18
View an entry in the phonebook	18
Dial an entry in the phonebook	19
Dial a speed dial number	19
Edit a name and number in the phonebook	19
Edit ringtone	19
Delete an entry in the phonebook	20
Delete entire phonebook	20
Copy an entry to another handset	20
Copy the entire phonebook to another handset	20
Copy an entry to a SIM card	21
Copy all entries to or from a SIM card	21
Change the dialling code	21

## Handset settings

Handset ringtone	22
Handset ringer volume	22
Handset name	22
Display language	23

Display contrast	23	Edit agenda	32
Display wallpaper	23	Send agenda as a text message	32
Menu colour	23	Delete agenda	33
Screensaver	24	Delete all agendas	33
Light timeout	24		
Auto talk	25	<b>Calls lists</b>	
Key beep	25	Caller Display / Calls lists	34
PABX access code	25	View new missed calls	34
		View and dial from a calls list	35
<b>Base settings</b>		Copy a Calls list number to the phonebook	35
Base ringtone	26	Send a text message to a Calls list number	35
Base ringer volume	26	Delete an entry in the Calls list	36
Dialling mode	26	Delete all entries in the Calls list	36
Ring priority	27		
Recall mode	27	<b>Call Waiting</b>	37
First ring	27		
System PIN	28	<b>BT Services</b>	
Restore default settings	28	Pre-stored BT Services numbers	38
		BT Helpline	38
		BT 118500 (Directory Enquiries)	38
		Call Divert on/off/check	39
<b>Clock &amp; alarm</b>		Call Waiting on/off/check	39
Date & time	29	Add or edit an entry	39
Set alarm	29	Delete an entry	40
Alarm on /off	29	Delete all entries	40
Time format	30		
Switch off alarm ring	30	<b>Answering machine</b>	
		Switch the answering machine on / off via handset and base	41
<b>Agenda</b>		Answer delay	41
Add a new event	31	Switch message alert beep on / off	41
Switch off agenda ring	31		
Show agenda details	32		

On-screen alert	42	Add or change Service Centre numbers	52
Record your own outgoing message via the handset	42	Set send centre	53
Check or delete your outgoing message	42	Message alert tone	53
Select outgoing message mode	43	Set message size	53
Record a memo	43	<b>Using additional handsets</b>	
Call screening	44	Registering an additional handset	54
Message playback via the base	44	Select a base	55
Message playback via the handset	44	De-register a handset	55
Delete all old messages	45	Internal calls	55
Remote access	45	Call another handset	55
Switch remote access PIN On or Off	45	Transfer a call	56
Change the remote access security PIN	45	3-Way conference call	56
Switch your answering machine on remotely	46	<b>Help</b>	57
Play messages	46	<b>General information</b>	
<b>Text messaging</b>		Safety information	63
Subscribe to the text messaging service	47	Cleaning	63
Cost of the fixed line service	47	Environmental	64
Send a text message	47	Product disposal instructions	64
Receiving and reading text messages	48	Guarantee	65
Read a new message	48	Returning your phone	66
Read, forward, delete, view and save numbers of texts in the Inbox	49	How many telephones can I have?	66
Edit or send texts in the Drafts box	50	R&TTE	66
Forward or delete texts in the Outbox	51	Declaration of Conformance	66
Edit templates	51	Connecting to a switchboard	66
Deleting texts	52	Inserting a pause	67
Service Centre numbers	52	Recall	67
		User Guide formats	67

# Getting started

## Location

You need to place your BT Synergy base within 2 metres of the mains power socket and telephone socket so that the cables will reach.

Make sure it is at least 1 metre away from other electrical appliances to avoid interference. Your BT Synergy works by sending radio signals between the handset and base. The strength of the signal depends on where you site the base. Putting it as high as possible ensures the best signal.

## Setting up

### Connect the base

1. Plug the mains power cable (item code 040497) into the socket marked  on the underside of the base and plug the other end into the mains power wall socket and switch the power on.

The telephone cable is pre-installed in the base but **do not** connect the other end to the telephone wall socket yet.

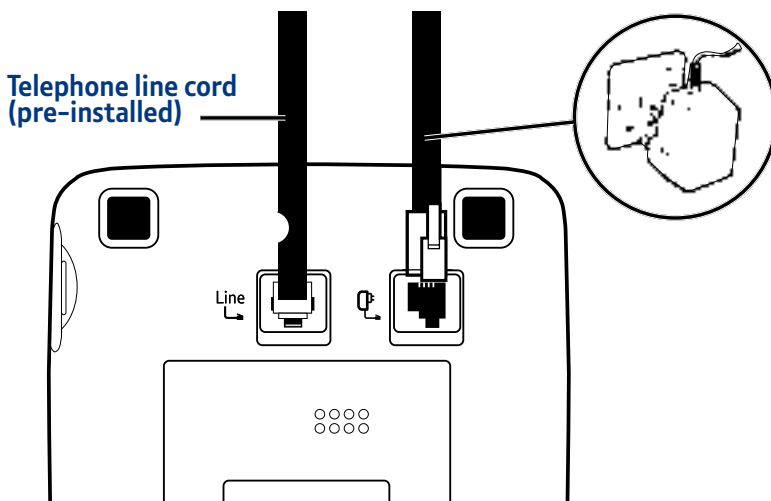



### WARNING

Do not place your BT Synergy in the bathroom or other humid areas.

### Handset range

The BT Synergy has a range of up to 300 metres outdoors when there is a clear line of sight between the base and handset. Any obstruction between the base and handset will reduce the range significantly. With the base indoors and handset either indoors or outdoors, the range will normally be up to 50 metres. Thick stone walls can severely affect the range.

### Signal strength

The  icon on your handset indicates when you are in range. When out of range of the base the  icon will flash and the out-of-range tone will sound every minute. This tone is repeated until you move back into range.

### IMPORTANT

The base station must be plugged into the mains power at all times. Do not connect the telephone line cord into the wall socket until the handset is fully charged. Only use the power and telephone cables supplied with the product.

## Install and charge the batteries

1. Make sure the battery ribbon is laying flat inside the compartment and insert the two batteries supplied observing the polarity markings (+ and -).
2. Attach the battery compartment cover by sliding the ends into the holes inside the compartment, pressing down and pushing the other end along until it clicks into place.
3. Place the handset on the base to charge for at least 24 hours. The red charging light comes on. When the handset is fully charged the display shows the  icon.

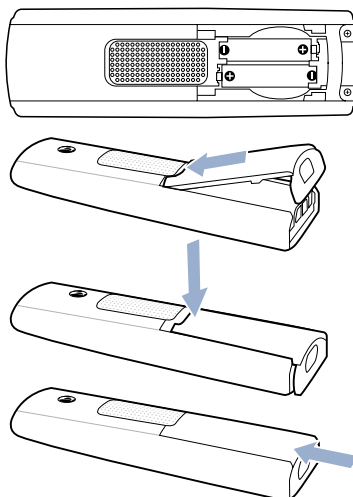

## Connect the telephone line

1. After 24 hours, plug the telephone line cord from the base into the telephone wall socket.

## Setting up for multiple packs

If you have purchased a multiple pack, this process will need to be carried out for all handsets and chargers:

1. Plug the mains power cable (item code 032765) into the socket marked  on the underside of the charger.

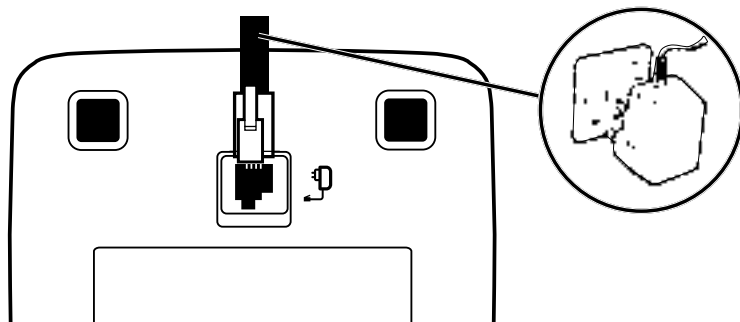

### Battery low warning

If the  icon flashes in the display you will need to recharge the handset before you can use it again.

During charging, the  icon will scroll in the display.

### Battery performance

In ideal conditions, fully charged batteries should give about 10 hours talk time or 100 hours standby time on a single charge.

Note that new batteries do not reach full capacity until they have been in normal use for several days.

To keep your batteries in the best condition, leave the handset off the base for a few hours at a time.

Running the batteries right down at least once a week will help them last as long as possible.

The charge capacity of rechargeable batteries will reduce with time as they wear out, giving the handset less talk/standby time. Eventually they will need to be replaced. New rechargeable batteries are available from the BT Synergy Helpline on 0800 145 6789\*.

After charging your handset for the first time, subsequent charging time is about 6–8 hours a day. Batteries and handset may become warm during charging. This is normal.

2. Activate the batteries as described previously on page 7.
3. Place the handset on the charger to charge for at least 24 hours. When the handset is fully charged the  icon will indicate that it is fully charged.

## Your BT Synergy 6500 is ready for use.

### Date and time

Providing you have subscribed to your network's Caller Display service, the date and time is set automatically for all handsets when you receive your first call. The date and time is recorded with each answering machine message you receive.

If you do not have a Caller Display service you can set the date and time manually. Please see page 29 for these instructions.

### Removing the batteries

If you ever need to remove the batteries, simply slide open the battery compartment cover and pull the ribbon away from the handset to release the batteries.

Only use rechargeable batteries as specified in this guide.



# Getting to know your phone

## Handset buttons

### Redial/Up

In standby, press to open and scroll through the Redial list, page 16.

In talk mode, press to increase volume.

In menu mode, press to scroll through the options.

When storing an entry in the phonebook, press and hold to enter a Pause, page 67.

### Option button (left)

Press to open the Menu.

Press to select options displayed on screen.

### Talk/Handsfree

In standby mode, press to make and receive calls, page 15.

In talk mode, press to switch handsfree on and off, page 16.

### Speed dial buttons

Once a number has been stored as a speed dial entry, press and hold to dial, page 19.

### \*

Press and hold to temporarily switch to tone dialling.

### R (Recall)

For use with switchboard/PBX and BT Calling Features.

### 0

Press to add a space when entering text.

### Option button (right)

Press to select options displayed on screen.

In menu mode, press to step back one screen.

In standby, press **Names** to open the phonebook menu.

### End call/ Power on/off

Press to end a call, page 15.

In menu mode, press to return to standby.

In standby, press and hold to switch the handset off. When off, press to switch the handset back on, page 15.

### Down/Phonebook

In standby, press to open and scroll through the Names list, page 18.

In talk mode, press to reduce volume.

In menu mode, press to scroll through the options.

### #/Lock

Press and hold to lock the keypad, page 17.

To unlock, select **Unlock** and follow the on screen instructions.

### Intercom

Used for internal calls, page 55.

### Microphone

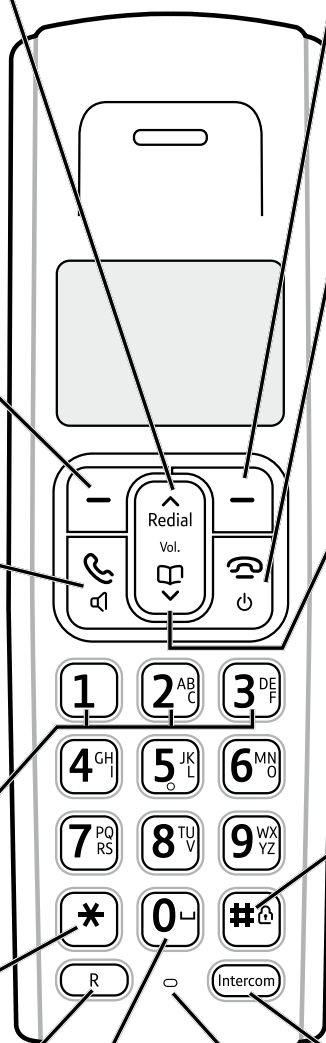

## Standby screen

### Range indicator

Flashes when out of range or not registered



Handset name/number

### Battery status

Scrolls when charging

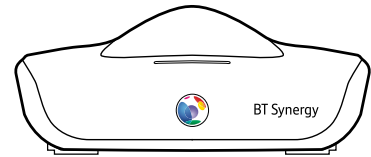

## Display icons



Displayed in standby mode to indicate handset is in range of the base. Flashes if you move out of range.



Battery is fully charged.



Battery is partially charged.



Battery is running low.



Battery is almost discharged.



Handset ringer volume is Off.



Displayed in handsfree talk mode.



Answering machine is On.



An alarm is set to On.



The keypad is locked.



You have answering machine messages.<sup>†</sup>



You have SMS text messages.\*<sup>†</sup>



You have missed calls.\*<sup>†</sup>

\* For this feature to work you must subscribe to your network provider's Caller Display service. A fee may be payable.

† The number underneath the icon indicates the number of messages or the number of missed calls received.

If you experience any problems, please call the Helpline on Freephone 0800 145 6789\* or email [bt.helpdesk@sgweurope.com](mailto:bt.helpdesk@sgweurope.com)

## Base

### Message counter LED

Indicates number of messages and shows status of answer machine:

- Answer Off
- R Answering Machine being accessed
- £ Date is not set
- F Answering machine full
- 9 (flashing) More than 9 messages

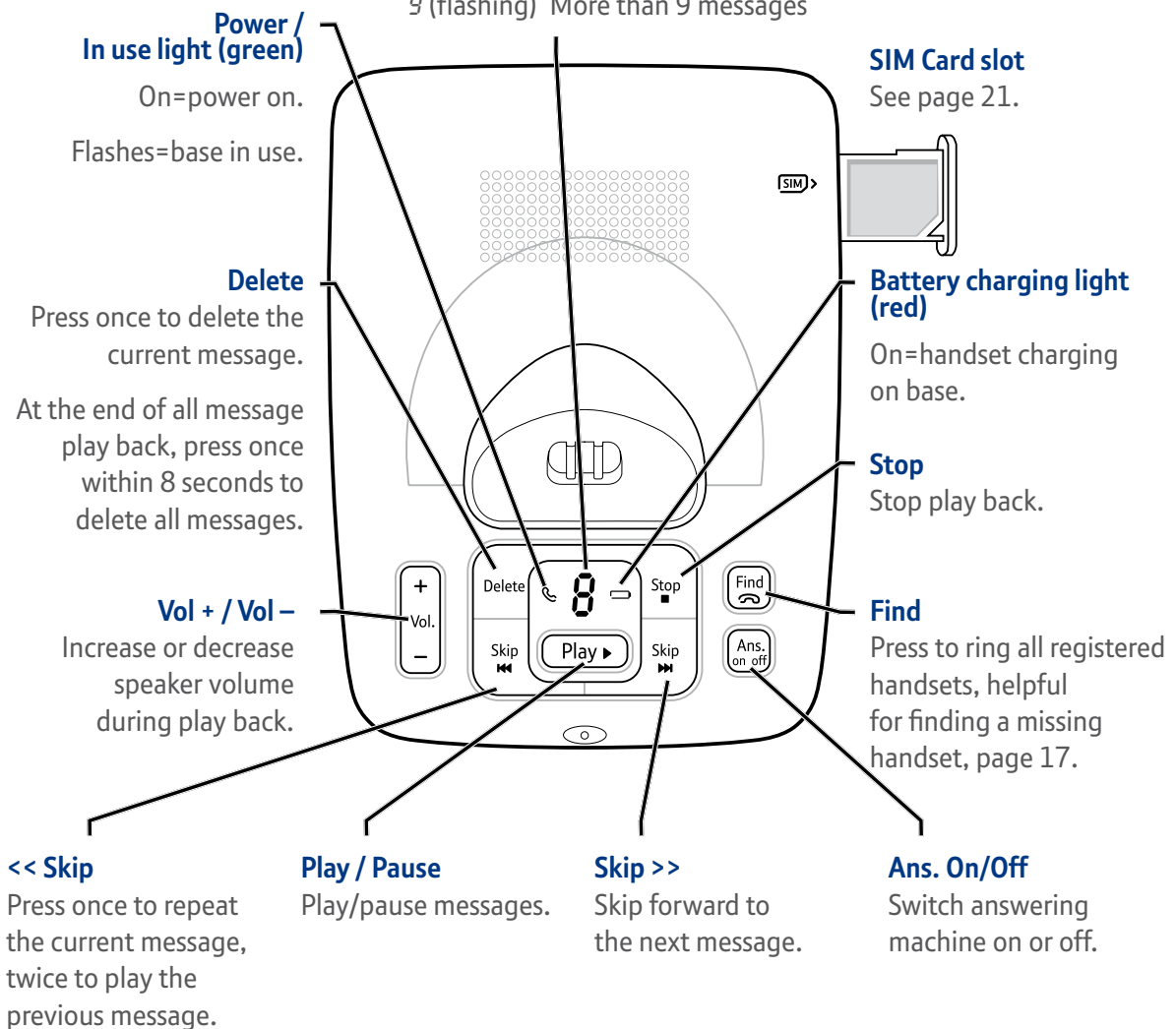



## Navigating the menu

Your BT Synergy 6500 has an easy to use menu system.

Each menu has a list of options, which you can see on the menu map on the following page.

When the handset is switched on and in standby:

1. Press **Menu** to open the main menu.
2. Then use  or  buttons to scroll through the available options.
3. Press the **Select** option button to select a menu option or the **Back** option button to go back to the previous screen.

To return to the previous menu level, press **Back**.

To exit the menu and return to standby press .

### Option buttons

Press to select the option displayed on the screen.

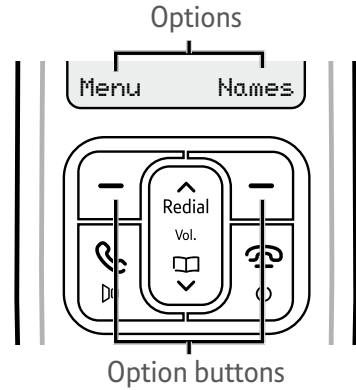

If no buttons are pressed for 30 seconds, the handset returns to standby automatically.

# Menu Map

## TEXT MESSAGING

Write Message  
Inbox  
Drafts  
Outbox  
Templates  
Delete Messages  
Text Settings

## ANSWER MACHINE

Play  
Play All  
Answer On/Off  
Record Memo  
Outgoing Message  
Delete Messages  
Answer Settings

## CALLS LIST

Missed Calls  
Received Calls  
Dialled Calls  
Delete calls

## AGENDA

Add Event

**The following options will only be displayed once an event has been stored:**

Add Event  
Show Details  
Edit Event  
Send as a Text  
Delete Event  
Del All Events

## BT SERVICES

BT Helpline  
BT 118500  
Divert on  
Divert off  
Divert check  
C wait on  
C wait off  
C wait check

## CLOCK & ALARM

Date & Time  
Alarm  
Time Format

## SETTINGS

### Set Handset

Ringtone  
Ringer Volume  
Handset Name  
Language  
Wallpaper  
Menu Colour  
Screensaver  
Light Timeout  
Display Contrast  
Auto Talk  
Key Beep  
PABX Access Code

### Set Base

Ringtone  
Ringer Volume  
Dialling Mode  
Ring Priority  
Recall Mode  
First Ring  
System PIN  
Factory Reset

## REGISTRATION

Register Handset  
Select Base  
De-register

## Names Menu

From menu in standby:

Search  
Add Entry  
Copy Phonebook  
Dialling Codes  
Memory Status  
Delete Phonebook

Press  in standby:

Phonebook Empty will be displayed if no entries are stored.

Select Options and the following list is displayed:

Show Details  
Send Message  
Edit Entry  
Copy Entry  
Ringtone  
Delete Entry  
Speed Dial

## Press Names during a call: Phonebook list is displayed.

Add Entry  
Show Details  
Edit Entry  
Delete Entry

## Character map

Button	Lowercase	Uppercase
<b>1</b>	. , - ? ! i ' @ : ; / 1	
<b>2<sup>AB</sup></b>	a b c 2 ä æ å à ç	A B C 2 Ä Æ Å Ç
<b>3<sup>DE</sup></b>	d e f 3 è é	D E F 3 É
<b>4<sup>GH</sup></b>	g h i 4 ì	G H I 4
<b>5<sup>JK</sup></b>	j k l 5	J K L 5
<b>6<sup>MN</sup></b>	m n o 6 ö ø ò ñ	M N O 6 Ö Ø Ñ
<b>7<sup>PQRS</sup></b>	p q r s 7 ß	P Q R S 7
<b>8<sup>TUV</sup></b>	t u v 8 ù ü	T U V 8 Ü
<b>9<sup>WXYZ</sup></b>	w x y z 9	W X Y Z 9
<b>0<sup>␣</sup></b>	0 ␣ (= space)	
<b>*</b>	bring up symbol table (in SMS text editing mode)	
<b>#<sup>△</sup></b>	short press to switch between Abc, abc, ABC and 123 mode	

# Using the phone

## Switch the handset on / off

1. In standby, press and hold  to switch the handset off.

When off, press  to switch back on, or put the handset back on its base.

## Make a call

1. Press .
2. When you hear the dial tone, dial the number.

## Preparatory dialling

1. Dial the number first. If you make a mistake press **Clear** to delete the last digit.
2. Press  to dial.

## End a call

1. Press .

Once you've pre-dialled a number, you can select **Options** to either save the number to your phonebook or to use when sending a text message.

## Receive a call

When you receive an external call, the phone rings. The display shows **External Call** and the caller's number or, if the number matches an entry stored in the phonebook, the name is displayed.

## To answer the call:

1. If your handset is on the base and Auto Talk is on, pick up the handset.

Or

If your handset is on the base and Auto Talk is off, pick up the handset and press .

Or

If your handset is off the base, press .

When you make a call, the green **In Use** light on the base flashes.

### Call timer

Your handset will automatically time the duration of all external calls. The handset display shows the call duration both during and for a few seconds after your call.

During a call, you can open the phonebook by pressing **Names**.

During Preparatory dialling (but before pressing the  button) you can press **Options** to either save the number to the phonebook or to send a text to that number.

### Out of range warning

When the handset moves out of range of the base, the screen shows **Searching...** the  flashes and the handset gives a warning beep.

If you are on a call, the line will hang up. Move back within range. The handset will automatically re-connect to the base.



### Auto Talk

If auto talk is set to **ON** you can just pick the handset up to answer a call.

If you have switched auto talk off, you will need to press  as well.

Auto Talk **ON** is the default setting. To switch Auto Talk on and off, see page 25.





## Adjust the earpiece /receiver volume

1. During a call, press  or  to increase the volume. The display shows the level.

## Secrecy

1. During a call, press **Secrecy**. The display shows **Secrecy On** and your caller cannot hear you.
2. Press **Off** to return to your caller.

## Make a handsfree call



1. Dial the number then press .
2. Press  again. The  icon is displayed and you hear your call over the handset loudspeaker.  
Press  to switch the call between the earpiece and the loudspeaker.
3. Press  to end the call.

## Answer a call handsfree



When the phone rings:

1. Press  twice to answer the call.





## Switch to handsfree during a call

1. During a call: press  to put the call on the loudspeaker. To switch handsfree off and return the call to the earpiece, press  again.

## Redial the last number called

1. Press  the last number you called is highlighted.
2. Press  to dial.

## Redial a number from the redial list

1. Press  the last number you called is displayed.
2. Press  or  to scroll to the number you want.
3. Press  to dial.



There are 8 volume settings, the default setting is level 4. Any change you make to the volume setting remains in place until adjusted again.

### Secrecy

During a call, you can use the secrecy function to talk to someone nearby without your caller hearing.

### Handsfree

Handsfree lets you talk to your caller without holding the handset. It also enables other people in the room to listen to your conversation over the loudspeaker.

During a handsfree call, press  or  to change the volume.

### Redial

The last 20 telephone numbers called are saved to a redial list. You can then select any of the numbers to redial, delete or copy to the phonebook.

Redial numbers can be up to 32 digits long.



## Save a number from the redial list to the phonebook

Please see page 35 for instructions, “Copy a Calls list number to the phonebook”, and select the Dialed calls option.

## Delete a redial number/delete all redial

Please see page 36 for instructions and select the **Dialed Calls** option.



## To lock the keypad

1. Press and hold . The  icon is displayed.

## To unlock the keypad:

1. Press **Unlock**. Display shows **Press # to Unlock Keys**.
2. Press  briefly while the display above is shown.

## Paging/Find handset

1. Press  on the base. All handsets registered to the base will ring and display **Paging Call**.
2. Press  on the base again to stop the ringing or, on any handset, press **Stop** or any button on the handset to stop all handsets ringing.

### Keypad lock

You can lock the keypad so that it cannot be used accidentally while carrying it around.

You will be able to dial the emergency numbers 999 and 112.

### Important



When the keypad is locked you can still answer incoming calls and operate the handset as normal. When the call is ended, the keypad lock comes on again.

You can alert a handset user that they are wanted or locate a missing handset.

Paging calls cannot be answered by a handset.







## 250 Name and number phonebook

### Store a name and number in the phonebook



1. From standby, press **Names**. The phonebook menu is displayed.
2. **Search** is highlighted. Scroll  to **Add Entry** and press **Select**.
3. Enter the name and press **OK**.
4. Enter the number and press **Save**.
5. Scroll  or  to the ringtone you want and press **Select**. The display shows <Name> Saved and returns to the phonebook menu.
6. Press **Back** to return to the previous menu level.

### Store an entry from the phonebook to a speed dial button

You can assign an entry from your phonebook to one of the speed dial buttons: **1**, **2<sup>nd</sup>** or **3<sup>rd</sup>** for ease of dialling. Speed dial button **1** is pre-programmed with 1571 but you can change this.

1. Press . The first entry is displayed.
2. Scroll  or  to the entry you want to assign to a speed dial button.
3. Press **Options** and scroll  to **Speed Dial** and press **Select**.
4. Scroll  or  to the button you want to store the entry under: **Key 1**, **Key 2** or **Key 3** and press **Select**.
5. The display will show **Assign** or **Clear Entry**, select **Assign** to save the number or **Clear Entry** to delete.

### View an entry in the phonebook

1. Press . The first entry is displayed.
2. Scroll  or  to the entry you want or search alphabetically.
3. Press **Options**. The display highlights **Show Details**.
4. Press **Select** to display the name, number and ringtone.
5. Press **Dial** to call the number or **Back** to return to the previous level.

You can store up to 250 names and numbers in the phonebook. Names can be up to 12 characters long and numbers up to 24 digits. You can also select different ring tones for phonebook entries.

When storing a name the first character is upper case and the rest lower case.

To change the case manually, press .

To store Pause, press and hold .

To store a Recall, press  (this can only be done for **Timed Break**).

### Store a name and number

If you subscribe to a Caller Display Service and want the name of your caller displayed instead of the number, enter the full telephone number including the dialling code .

You can store multiple entries with the same name but you cannot store the same number more than once.

### Entering names

Use the keypad letters to enter names, e.g. to store TOM:

Press **8<sup>th</sup>** once to enter T.

Press **6<sup>th</sup>** three times to enter O.

Press **6<sup>th</sup>** once to enter M.

### Writing tips

Press **Clear** to delete the last character or digit.

Press  or  to move backwards or forwards through character/digits.





Press  to switch between upper and lower case.

Press **0<sup>th</sup>** to insert a space.

Use **0<sup>th</sup>** or **1** for other punctuation characters. See page 14 for a full character map.

You must enter a name to go with a number or the entry will not be saved.







## Dial an entry in the phonebook

1. In standby, press . The first entry is displayed.
2. Scroll  or  to the entry you want or search alphabetically.
3. Press  to dial the displayed number.







## Dial a speed dial number

1. Press and hold the button (**1**, **2<sup>nd</sup>** or **3<sup>rd</sup>**) under which you stored the entry. The number is dialled automatically.

## Edit a name and number in the phonebook

1. Press .
2. Scroll  or  to the entry you want.
3. Press **Options** and scroll  to **Edit Entry** and press **Select**.
4. Press **Clear** to delete characters, use the keypad to enter new ones then press **OK**.
5. Press **Clear** to delete digits, use the keypad to enter new ones then press **Save**.
6. Scroll  or  to the ringtone you want and press **Select** to save the entry.
7. Press **Back** to return to the previous menu level.

## Edit ringtone

1. Press .
2. Scroll  or  to the entry you want.
3. Press **Options** and scroll  to **Ringtone** and press **Select**.
4. Scroll  or  to the ringtone you want and select **OK** to save the entry.
5. Press **Back** to return to the previous menu level.

## Search alphabetically

Press   
 Or  
 Press **Names**.  
 Search is highlighted.  
 Press **Select**. The list of entries is displayed.

Enter the first letter of the name you want. The first name beginning with that letter is displayed.

Scroll  to view any other entries beginning with that letter.





## Open the phonebook during a call.

1. During your conversation, press **Names**.
2. Use the menu to select **Add Entry**, **Show Details**, **Edit Entry** or **Delete Entry**.



## Store a name and number via Preparatory dialling

During Preparatory dialling (but before pressing the  button) you can press **Options** to either save the number to the phonebook or to send a text to that number. See 'Preparatory dialling', page 15.







## Delete an entry in the phonebook

1. Press .
2. Scroll  or  to the entry you want.
3. Press **Options** and scroll  to **Delete Entry** and press **Select**.
4. Press **Yes** to confirm or **No** to cancel.
5. Press **Back** to return to the previous menu level.

## Delete entire phonebook



1. Press **Names**.
2. Scroll  or  to **Delete Phonebook** and press **Select**.
3. Press **Yes** to confirm or **No** to cancel.
4. Press **Back** to return to the previous menu level.

## Copy an entry to another handset

1. Press .
2. Scroll  or  to the entry you want.
3. Press **Options** and scroll  to **Copy Entry** and press **Select**.
4. **To Handset** is displayed. Press **Select**.
5. Available handsets are displayed. Scroll  or  to the handset you want and press **Select**. **Copy Phonebook?** is prompted on the receiving handset. Press **Yes** to accept or **No** to cancel. When completed the display shows **1 Entry Copied**.
6. Press **Back** to return to the previous menu level.

## Copy the entire phonebook to another handset

At the handset you are copying from:

1. Press **Names**.
2. Scroll  to **Copy Phonebook** and press **Select**.
3. **To Handset** is displayed. Press **Select**.
4. Available handsets are displayed. Scroll  or  to the handset you want and press **Select**. When completed the display shows the number of entries copied.
5. Press **Back** to return to the previous menu level.

At the receiving handset:

The display shows **Copy Phonebook?** Press **Yes** to begin copying or **No** to cancel.

## Delete a speed dial entry

Follow the instructions on page 18 under “Store an entry from the phonebook to a speed dial button” and choose the **Clear Entry** option to delete.

When you have more than one handset registered to your BT Synergy 6500 base, you can copy entries between handsets.



In just a few minutes, you can copy all your phonebook contacts to another handset.

## Memory status



You can check how much of the phonebook memory is available.

1. Press **Names**.
2. Scroll  to **Memory Status** and press **Select**.
3. Display shows the number of **Used** and **Free** entries.
4. Press **Back** to return to the previous menu level.



## Copy an entry to a SIM card

1. Insert the SIM card into the SIM READER slot on the side of the base.
2. Press  to open the phonebook list then press **Options**.
3. Scroll  to **Copy Entry** and press **Select**.
4. Scroll  to **To SIM** and press **Select**.
5. If requested, enter your SIM PIN then press **OK**.
6. Display shows **Please wait...X%** as it copies entries from the SIM. When completed the display shows **<Name> Copied**.
7. Press **Back** to return to the previous menu level.

## Copy all entries to or from a SIM card

1. Insert the SIM card into the SIM READER slot on the side of the base.
2. Press **Names**.
3. Scroll  to **Copy Phonebook** and press **Select**.
4. Scroll  to either **From SIM** or **To SIM** and press **Select**.
5. If requested, enter your SIM PIN then press **OK**.
6. Display shows **Copying** and the name of each entry. When completed the display shows the number of entries.
7. Press **Back** to return to the previous menu level.

## Change the dialling code

1. Press **Names**.
2. Scroll  to **Dialling Codes** and press **Select**.
3. Scroll  to the part of the dialling code you need to change, **International**, **Country** or **Local** and press **Select**.
4. Enter the new code and press **Save**.
5. Press **Back** to return to the previous menu level.

### Important

Make sure your numbers are stored on the SIM card and not just on the mobile itself, otherwise copying will not work.

While SIM copying is taking place do not replace the handset on the base as this will stop the transfer.

However, if an incoming call is received, the copying process is cancelled so that the call can be taken.

The PIN number will be displayed as asterisks for security reasons.

If the memory becomes full during copying from a SIM, the display shows **Memory Full Not All Copied**.

Most SIM cards are supported, but if the SIM Card format is not compatible, the display shows **SIM Format Not Supported**.

When copying from a SIM only the first 12 characters of each name are copied and the first 24 digits in a number are copied.

If an entry with a duplicate number is found, the entry will not be copied.

**Please Insert SIM Card** will be displayed if you have not already inserted a SIM card into the base.





### Local code

The Dialling Codes function automatically converts SIM entries beginning with international dialling codes to the local code. For example, on a SIM card, + is the international code and 44 is the country code. These will be replaced automatically by the local code 0 so that a number beginning +44207 will be converted to 0207.





You should not normally need to alter this setting if you are using your BT Synergy in the UK and your mobile to call UK numbers. If this is not the case, then please call the BT Synergy Helpline for assistance on 0800 145 6789\*.

# Handset settings



## Handset ringtone

1. Press **Menu**, scroll  to **Settings** and press **Select**.
2. **Set Handset** is highlighted. Press **Select**.
3. **Ringtone** is highlighted. Press **Select**.
4. Press  **Redial** or  to highlight **External Call** or **Internal Calls**. Press **Select** to confirm.
5. Scroll  **Redial** or  to highlight the ringtone you want.
6. Press **Select** to confirm.
7. Press **Back** to return to the previous menu level.

## Handset ringer volume

1. Press **Menu**, scroll  to **Settings** and press **Select**.
2. **Set Handset** is highlighted. Press **Select**.
3. Scroll  to **Ringer Volume** and press **Select**.
4. Press  **Redial** or  to display the volume level you want. Press **Select** to confirm.
5. Press **Back** to return to the previous menu level.

## Handset name

1. Press **Menu**, scroll  to **Settings** and press **Select**.
2. **Set Handset** is highlighted. Press **Select**.
3. Scroll  to **Handset Name** and press **Select**.
4. Use the keypad to enter the name and press **Save**.
5. Press **Back** to return to the previous menu level.

You can set different ringtones for external calls and internal calls.

Select from 20 handset ringtones.

You will hear a sample ring for each one you highlight (if the ringer is not switched off).

The handset has 5 ringer volume settings plus Off.





If the volume is set to Off the  icon is displayed.

The default setting is level 3.





If you are using more than one handset with your BT Synergy base, you can give each handset a personalised name to easily distinguish between the handsets.

A name can be up to 10 characters long.





## Display language

1. Press **Menu**, scroll  to **Settings** and press **Select**.
2. **Set Handset** is highlighted. Press **Select**.
3. Scroll  to **Language** and press **Select**.
4. Scroll  or  to the language you want and press **Select**.
5. Press **Back** to return to the previous menu level.





## Display contrast

1. Press **Menu**, scroll  to **Settings** and press **Select**.
2. **Set Handset** is highlighted. Press **Select**.
3. Scroll  to **Display Contrast** and press **Select**.
4. Scroll  or  to **Low**, **Medium** or **High** then press **Select**.
5. Press **Back** to return to the previous menu level.

## Display wallpaper





1. Press **Menu**, scroll  to **Settings** and press **Select**.
2. **Set Handset** is highlighted. Press **Select**.
3. Scroll  to **Wallpaper** and press **Select**.
4. Scroll  or  to the Wallpaper you want and press **Select**.
5. Press **Back** to return to the previous menu level.

## Menu colour





1. Press **Menu**, scroll  to **Settings** and press **Select**.
2. **Set Handset** is highlighted. Press **Select**.
3. Scroll  to **Menu Colour** and press **Select**.
4. Scroll  or  to select the colour you want: blue, orange or pink and press **Select**.
5. Press **Back** to return to the previous menu level.

The available languages include:  
English, Francais, Deutsch, Italiano  
and Espanol.

## Screensaver

1. Press **Menu**, scroll  to **Settings** and press **Select**.
2. **Set Handset** is highlighted. Press **Select**.
3. Scroll  to **Screensaver** and press **Select**.
4. Scroll  or  to set the Screensaver to **Clock** or **Off**.
5. Press **Select** to select **Clock**.
6. Press **Back** to return to the previous menu level.

## Light timeout

1. Press **Menu**, scroll  to **Settings** and press **Select**.
2. **Set Handset** is highlighted. Press **Select**.
3. Scroll  to **Light Timeout** and press **Select**.
4. Scroll  or  to set the timeout period you want then press **Select**.
5. Press **Back** to return to the previous menu level.





When the screensaver is set to **Clock** an analogue clock is displayed.

The screensaver comes on when the screen backlight switches off in standby mode. To change the backlight timeout setting, see below.





Set how long the backlight stays on after the last button press.







## Auto talk

1. Press **Menu**, scroll  to **Settings** and press **Select**.
2. **Set Handset** is highlighted. Press **Select**.
3. Scroll  to **Auto Talk** and press **Select**.
4. Scroll  or  to **On** or **Off** then press **Select**.
5. Press **Back** to return to the previous menu level.

## Key beep

1. Press **Menu**, scroll  to **Settings** and press **Select**.
2. **Set Handset** is highlighted. Press **Select**.
3. Scroll  to **Key Beep** and press **Select**.
4. Scroll  or  to **Off** or **On** then press **Select**.
5. Press **Back** to return to the previous menu level.



## PABX access code

1. Press **Menu**, scroll  to **Settings** and press **Select**.
2. **Set Handset** is highlighted. Press **Select**.
3. Scroll  to **PABX Access Code** and press **Select**.
4. Scroll  or  to **On**, **Off** or **Set Code** then press **Select**.

If you select **Set Code**, enter the switchboard access code e.g. 9 then press **Save**.

5. Press **Back** to return to the previous menu level.

With Auto talk ON, when the phone rings you can answer it by simply lifting the handset from the base station. Similarly, a dialled call can be ended by placing the handset back on to the base station.

With Auto talk Off, you need to press the  button to answer incoming calls even after lifting the handset from the base station. To end a call the  button must be used.





Keybeeps are turned off by default.

Where your BT Synergy 6500 is installed as an extension to a PBX or switchboard, you can enable the PABX access code feature, with the code normally used to obtain an outside line on the PABX (typically 9).





Your BT Synergy will then **automatically** prefix any entry dialled from the phonebook, redial or calls list with the PABX access code.

# Base settings





## Base ringtone

1. Press **Menu**, scroll  to **Settings** and press **Select**.
2. Scroll  to **Set Base** and press **Select**.
3. **Ringtone** is highlighted. Press **Select**.
4. Scroll  or  to highlight the ringtone you want.
5. Press **Select** to confirm.
6. Press **Back** to return to the previous menu level.

## Base ringer volume

1. Press **Menu**, scroll  to **Settings** and press **Select**.
2. Scroll  to **Set Base** and press **Select**.
3. Scroll  to **Ringer Volume** and press **Select**.
4. Press  or  to display the volume level you want and press **Select** to confirm.
5. Press **Back** to return to the previous menu level.

## Dialling mode

1. Press **Menu**, scroll  to **Settings** and press **Select**.
2. Scroll  to **Set Base** and press **Select**.
3. Scroll  to **Dialling Mode** and press **Select**.
4. Press  or  to highlight **Pulse** or **Tone** then press **Select** to confirm.
5. Press **Back** to return to the previous menu level.





Select from 5 base ringtones.



You will hear a sample ring for each one you highlight (if the ringer is not switched off).



The base has 5 ringer volume settings plus Off. The default setting is level 5.

Your BT Synergy is pre-set to Tone dialling. You should not normally need to change this setting. The dial mode options are Tone (Time Break/Earth) or Pulse (Earth).

## Ring priority





1. Press **Menu**, scroll  to **Settings** and press **Select**.
2. Scroll  to **Set Base** and press **Select**.
3. Scroll  to **Ring Priority** and press **Select**.
4. Press  or  to highlight **All Handsets** or **Select Handset** then press **Select**.

If you choose **Select Handset** all available handsets are displayed. Scroll  or  to highlight the handset you want then press **Select**.





Scroll  or  to the number of rings you want to set 2, 4 or 6 and press **Select**.

5. Press **Back** to return to the previous menu level.

## Recall mode

1. Press **Menu**, scroll to **Settings** and press **Select**.
2. Scroll  to **Set Base** and press **Select**.
3. Scroll  to **Recall Mode** and press **Select**.
4. Press  or  to highlight **Timed Break** or **Earth** then press **Select** to confirm.
5. Press **Back** to return to the previous menu level.

## First ring

1. Press **Menu**, scroll  to **Settings** and press **Select**.
2. Scroll  to **Set Base** and press **Select**.
3. Scroll  to **First Ring** and press **Select**.
4. Press  or  to **On** or **Off** then press **Select** to confirm.
5. Press **Back** to return to the previous menu level.

When you have more than one handset registered to your base, you can set one handset to ring before the other handsets. This allows one handset user to answer all incoming calls first, like a receptionist.

Choose **All Handsets** if you want all handsets to ring at the same time or **Select Handset** to nominate a handset to ring two times before the others.



The default setting is **All Handsets**.

If you have subscribed to your network's Caller Display service, your BT Synergy does not ring until the caller information has been received and displayed.



However, if you want your handset to ring without waiting for the caller information to be displayed, set **First Ring** to **On**. Please note that this will mean the first ring you hear will be the default ringtone. This will change to any ringtone you have set once the caller information is displayed.

The default setting is **ON**.

## System PIN

1. Press **Menu**, scroll  to **Settings** and press **Select**.
2. Scroll  to **Set Base** and press **Select**.
3. Scroll  to **System PIN** and press **Select**.
4. Enter the old PIN (original setting 0000) and press **OK**.
5. Enter the new PIN and press **OK**.
6. Re-enter the new PIN and press **OK**.
7. Press **Back** to return to the previous menu level.

## Restore default settings

1. Press **Menu**, scroll  to **Settings** and press **Select**.
2. Scroll  to **Set Base** and press **Select**.
3. Scroll  to **Master Reset** and press **Select**.
4. Select **Yes** to confirm or **No** to cancel.
5. Enter the system PIN (original setting 0000) then press **OK**.  
The display will show **Reset Complete** then return to standby.

The System PIN is used when changing certain settings and registration / de-registration. The default setting is 0000. You can change this to your own preferred number up to 8 digits.

When you enter a PIN the digits are shown as \*\*\*\*.

You can restore your BT Synergy to its default (original) settings.

It will not affect the phonebook, calls list or user's data, including personal/recorded outgoing messages and answer machine messages.

All handsets registered to the base will be retained.

All text, answer machine, handset and base settings will be reset.







# Clock & alarm

## Date & time





If you subscribe to your network's Caller Display service, the base sets the date and time for all handsets whenever a call is received. You can manually set the time on an individual handset.

1. Press **Menu**, scroll  to **Clock & Alarm** and press **Select**.
2. **Date & Time** is highlighted, press **Select**.
3. Enter the date using the format DD/MM/YY and press **Save**.
4. Enter the time and press **Save**.
5. Press **Back** to return to the previous menu level.

## Set alarm

1. Press **Menu**, scroll  to **Clock & Alarm** and press **Select**.
2. Scroll  to **Alarm** and press **Select**.
3. Press  or  to select **On** and press **Select**.
4. Press  or  to select **Once**, **Mon-Fri** or **On Daily** and press **Select**.
5. Enter the time you want the alarm and press **Save**.
6. Press **Back** to return to the previous menu level.

## Alarm on /off

1. Press **Menu**, scroll  to **Clock & Alarm** and press **Select**.
2. Scroll  to **Alarm** and press **Select**.
3. Press  or  to select **On** or **Off** and press **Select**.
4. Press **Back** to return to the previous menu level.

You can set the time to either 12 or 24 hour format, see page 30.

When the alarm is set, the display shows the  icon.

Each handset can have a different alarm setting.

Once an alarm has been set, you can switch the setting on or off.





If the alarm was set to **Once** the  will disappear from the screen.

If set to **On Daily** or **Mon-Fri** the  will remain on the screen.

If you are using the handset to make a call when the alarm ring is due, the  flashes and you hear a beep in the earpiece.

## Time format

Set the time format to 12 or 24 hour setting.









1. Press **Menu**, scroll  to **Clock & Alarm** and press **Select**.
2. Scroll  to **Time Format** and press **Select**.
3. Press  or  to select **12 Hour** or **24 Hour** and press **Select**.
4. Press **Back** to return to the previous menu level.

## Switch off alarm ring

1. When the alarm goes off, press **Stop**.

# Agenda

## Add a new event

1. Press **Menu**, scroll  to **Agenda** and press **Select**.
2. If no previous event is stored, **Add Event** is highlighted press **Select**.  
Or  
If events are already stored, they are listed. Press **Options**. **Add Event** is highlighted. Press **Select**.
3. Enter the subject and press **Save**.
4. Enter the date (DD/MM).
5. Enter the time (HH:MM) and press **Save**. If the current time format setting is 12 hour, select am or pm by pressing  or .
6. Press  or  to select **Silent** or **Alarm** and press **Select**.  
If you press **Alarm**:  
Scroll  or  to select **Once** or **Annually** and press **Select**.  
Scroll  or  to select when you want to receive the reminder **At event time** or **30 min before**, press **Select**.  
Display shows **Saved**.
7. Press **Back** to return to the previous menu level.

## Switch off agenda ring

1. The event is displayed. Press **View** to stop the alarm and see the details of the event. Or press **Back** to stop the alarm and return to the standby screen. If no button is pressed, the alarm stops after one minute.



Use your BT Synergy to remind you of details of up to five events such as birthdays, anniversaries or appointments. The entry can be up to 24 characters long.

Up to 24 characters can be entered as the subject.





If you select a silent reminder, the event subject is displayed on screen but no alarm will sound.

When the event memory is full, the display shows **Memory Full**. You must delete an event before you can add a new one.



## Show agenda details



1. Press **Menu**, scroll  to **Agenda** and press **Select**.
2. Stored events are displayed. If required, scroll  to the event you want and press **Options**.
3. Scroll  to **Show Details** and press **Select**. The description, date and time of the reminder are displayed.
4. Press **Back** to return to the previous menu level.

## Edit agenda

1. Press **Menu**, scroll  to **Agenda** and press **Select**.
2. Stored events are displayed. If required, scroll  to the event you want and press **Options**.
3. Scroll  to **Edit Event** and press **Select**.
4. Edit the subject and press **Save**.
5. Edit the date and time then press **Save**.
6. Press  or  to select **Silent** or **Alarm** and press **Select**.

If you press **Alarm**:



Scroll  or  to select **Once** or **Annually** and press **Select**.

Scroll  or  to select when you want to receive the reminder **At event time** or **30 min before**, press **Select**.

Display shows **Saved**.



7. Press **Back** to return to the previous menu level.

## Send agenda as a text message



1. Press **Menu**, scroll  to **Agenda** and press **Select**.
2. Stored events are displayed. Scroll  to the event you want and press **Options**.
3. Scroll  to **Send as a Text** and press **Select**.
4. The event is displayed. Press **Options** to select **Send** option and enter a destination number.



## Delete agenda

1. Press **Menu**, scroll  to **Agenda** and press **Select**.
2. Stored events are displayed. Scroll  to the event you want and press **Options**.
3. Scroll  to **Delete Event** and press **Select**.
4. Press **Yes** to confirm or **No** to cancel.
5. Press **Back** to return to the previous menu level.

## Delete all agendas

1. Press **Menu**, scroll  to **Agenda** and press **Select**.
2. Stored events are displayed. Press **Options**.
3. Scroll  to **Delete All Events** and press **Select**.
4. Press **Yes** to confirm or **No** to cancel.
5. Press **Back** to return to the previous menu level.

# Calls lists

## Caller Display

If you have subscribed to a Caller Display Service, you will be able to see your caller's number on your handset display (provided it is not withheld) prior to answering the call.

If your caller's name and number are stored in the phonebook and a name/number match is found, you will see the caller's name on the display instead.

## Calls lists



Each handset can hold details of up to 30 answered or unanswered calls and 20 dialled calls.

The caller's details are stored in a Calls list whether you answered the call or not. When the list is full, and a new call is received, the oldest entry will be deleted automatically.

## New calls alert

When you have missed calls, the standby display shows **You have X new calls**. If you press **Back**, the message disappears and is replaced with the  icon and the number of missed calls is displayed underneath.

## View new missed calls

1. When you see the new calls alert, press **View**. You can now scroll  or  through the **Missed Calls list**.
2. Press **Options**. **Show Details** is highlighted. Press **Select** to see the details.
3. Press **Back** to return to the previous menu level.

### IMPORTANT

To use Caller Display you must first subscribe to the service from your network provider. A quarterly fee may be payable. For more information on BT Calling Features call BT free on 0800 800 150.

To ensure the caller's name is displayed, make sure you have stored the full telephone number, including the dialling code in the phonebook.

If the caller's number is stored in the phonebook, the name assigned to it is displayed.



If the number is unavailable, **Unavailable** will be displayed.

If the call is from an international number, **International** will be displayed.

If the call is from the operator, **Operator** will be displayed.





If the call is from a payphone, **Payphone** will be displayed.

If the call is from a ringback request, **Ringback** will be displayed.









Use the  and  buttons to toggle between showing the number or the number plus the time and date.

New calls in the calls list have a large dot next to them to indicate that they haven't been viewed yet.







## View and dial from a Calls list

1. Press **Menu**, scroll  to **Calls Lists** and press **Select**. **Missed Calls** is highlighted. Scroll  or  to choose **Missed Calls**, **Received Calls** or **Dialled Calls**.
2. Press **Select**. You can now scroll  or  through the list.
3. Press **Options**. **Show Details** is highlighted.
4. Press **Select** to see the caller's details.
5. Press **Dial** to call the number.
6. Press **Back** to return to the previous menu level.

## Copy a Calls list number to the phonebook

1. Press **Menu**, scroll  to **Calls Lists** then press **Select**. **Missed Calls** is highlighted.  
If required, scroll  or  to **Received** or **Dialled Calls** then press **Select**.
2. Scroll  or  to the entry you want and press **Options**.
3. Scroll  to **Save Number**. Press **Select**.
4. Enter a name then press **OK**. The number is displayed, press **Save**.
5. Scroll  or  to the ringtone you want and press **Select**.
6. Press **Back** to return to the previous menu level.

## Send a text message to a Calls list number







1. Press **Menu**, scroll  to **Calls Lists** then press **Select**. **Missed Calls** is highlighted. If required, scroll  or  to **Received** or **Dialled Calls** then press **Select**.
2. Scroll  or  to the entry you want and press **Options**.
3. Scroll  to **Send Message**. Press **Select**.
4. Write the message then press **Options**.
5. **Send** is highlighted. Then press **Select**. (You can save, insert a symbol, emoticon or template).
6. The number is pre-entered on the **Send** to screen, press **Send** to send the message.
7. Press **Back** to return to the previous menu level.

See 'Entering names' and 'Writing tips' on page 18.





If you need to edit the number, use **Clear** to delete any unwanted digits, then enter new ones using the keypad.

See page 47 for more information on text messaging.

## Delete an entry in the calls list

1. Press **Menu**, scroll  to **Calls Lists** then press **Select**. **Missed Calls** is highlighted. If required, scroll  or  to **Received** or **Dialled Calls** then press **Select**.
2. Scroll  or  to the entry you want and press **Options**.
3. Scroll  to **Delete Call**. Press **Select**.
4. Press **Back** to return to the previous menu level.



## Delete all entries in the calls list

1. Press **Menu**, scroll  to **Calls List** then press **Select**. **Missed Calls** is highlighted. If required, scroll  or  to **Delete Calls** press **Select**.
2. Scroll  or  to highlight **Missed Calls**, **Received Calls**, **Dialled Calls** or **All Calls**. Press **Select**.
3. Press **Yes** to confirm or **No** to cancel.
4. Press **Back** to return to the previous menu level.

You can delete all entries in an individual Calls list or all entries from all Calls lists.

# Call Waiting

## Call Waiting

1. During a call, you hear a soft beep in the earpiece and the display shows the number of the caller or the name if it matches an entry in your phonebook. If these are not available, the display shows **Call Waiting**.
2. Press  to put your current caller on hold and speak to the new caller.
3. Press  again to switch between both callers.
4. Press  to finish the current call.

You must subscribe to your network's Caller Display service for Call Waiting to work. A quarterly fee may be payable.

See page 39 for instructions on how to switch your Call Waiting service on or off.

# BT Services



By selecting the BT Services menu you can access a range of useful pre-stored numbers and further BT Calling Features.

Up to 22 entries are available in the Useful Numbers directory. The spare entries can be handy for storing important services such as the number of your Doctor or Dentist.

## Pre-stored BT Services numbers:

- BT Helpline
- BT 118500
- Divert on
- Divert off
- Divert check
- C wait on
- C wait off
- C wait check

### BT Helpline

1. Press **Menu** then scroll  to **BT Services** and press **Select**.
2. **BT Helpline** is highlighted. Press  to dial or press **Options**. **Show Details** is highlighted, press **Select** to view.

### BT 118500 (Directory Enquiries)

1. Press **Menu** then scroll  to **BT Services** and press **Select**.
2. Scroll  to **BT 118500**. Press  to dial or press **Options**. **Show Details** is highlighted, press **Select** to view.

### IMPORTANT

To use BT Services and BT Calling Features you must first subscribe (if required) to the relevant service from your network provider. A quarterly fee may be payable.

#### Please note

Some of these services are chargeable e.g. BT 118 500 and Call Divert.



For more details on BT's Calling Features, call BT free on 0800 800 150.

If you are not connected to the BT network, some of these services may not be available. Please contact your network provider. Call Diversion services may allow other divert options. Check with your network provider for details.



For further information, see the BT Calling Features user guide supplied when you subscribe to the services of your choice.

## Call Divert on/off/check



Call Divert will divert all incoming calls to another number of your choice.

1. Press **Menu** then scroll  to **BT Services** and press **Select**.
2. Scroll  to **Divert on**, **Divert off** or **Divert check**. Press  to dial or press **Options**.
3. **Show Details** is highlighted. Press **Select** to view.

## Call Waiting on/off/check

1. Press **Menu** then scroll  to **BT Services** and press **Select**.
2. Scroll  to **C wait on**, **C wait off** or **C wait check**. Press  to dial or press **Options**.
3. **Show Details** is highlighted. Press **Select** to view.

## Add or edit an entry

1. Press **Menu** then scroll  to **BT Services** and press **Select**.
2. Scroll  to the entry you want. Press **Options**.
3. Scroll  to **Edit Entry**. Press **Select**.
4. Enter the name you want and press **Save**.
5. Enter the number you want and press **Save**.
6. Press **Back** to return to the previous menu level.

If you use this feature you will pay for the cost of the diverted call.



Call Waiting lets you know if another person is trying to contact you while you are on a call. If a second caller rings you will hear a beep in the handset. Providing you have also subscribed to Caller Display, the screen will show the caller's details.

See page 37 for instructions on how to use Call Waiting.



You can edit existing entries or use an 'empty' slot to enter your own preferred number in the Useful Numbers directory.

Names can be up to 12 characters and numbers up to 24 digits long.

## Delete an entry

1. Press **Menu** then scroll  to **BT Services** and press **Select**.
2. Scroll  to the entry you want and press **Options**.
3. Scroll  to **Delete Entry** and press **Select**.
4. Press **Yes** to confirm or **No** to cancel.
5. Press **Back** to return to the previous menu level.







## Delete all entries

1. Press **Menu** then scroll  to **BT Services** and press **Select**.
2. Press **Options**.
3. Scroll  to **Delete All** and press **Select**.
4. Press **Yes** to confirm or **No** to cancel.
5. Press **Back** to return to the previous menu level.





# Answering machine







## Switch the answering machine on / off via the handset

1. Press **Menu**, scroll  to **Answer Machine** and press **Select**.
2. Scroll  to **Answer On/Off** and press **Select**.
3. Scroll  or  to highlight **On** or **Off** and press **Select**.  
When switched on the handset display shows  in idle.
4. The new setting is announced and your outgoing message is played. To stop listening to the outgoing message, press .







## Switch the answering machine on / off via the base

1. Press . The new setting is announced and your outgoing message is played. To stop listening to the outgoing message, press the  button.

## Answer delay

1. Press **Menu**, scroll  to **Answer Machine** and press **Select**.
2. Scroll  to **Answer Settings** and press **Select**.
3. Scroll  or  to **Answer Delay** and press **Select**.
4. Scroll  or  to the setting you want and press **Select**.
5. Press **Back** to return to the previous menu level.

## Switch message alert tone on / off

1. Press **Menu**, scroll  to **Answer Machine** and press **Select**.
2. Scroll  to **Answer Settings** and press **Select**.
3. Scroll  or  to **Message Alert** and press **Select**.
4. Scroll  or  to highlight **On** or **Off** and press **Select**.
5. Press **Back** to return to standby.

Your BT Synergy can digitally record up to 30 minutes of messages or up to 59 messages. Each message can last up to a maximum of 3 minutes. As well as recording incoming messages, you can record memos for other users.

You can operate your answering machine from:

- the handset or the base.
- remotely, from any other Touchtone™ telephone, see page 45.

Your BT Synergy comes with two pre-recorded outgoing messages, **Answer and Record** or **Answer Only**, but if you wish you can record your own.

You will need to set the date and time (if you have not already done so) so that you will know when each message was received, see page 29. (The default day and time setting is 01/01/10 12:00PM.)

Answer delay sets the number of times your BT Synergy will ring before the answer machine picks up your call and starts playing the outgoing message. You can change this setting to between 2–9 rings or **Time Saver**. The default setting is 6 rings.

For compatibility with BT 1571 or another voicemail service it is advisable to keep to the default setting or lower.



For information on **Time Saver**, see **Switch your answering machine on remotely**, page 46.

### Message alerts

When you have new messages, with the audible message alert switched on, you will hear an audible alert once at the handset. The default setting is **Off**.

## On-screen alert





When you have new answering machine messages, the screen shows **You have X new messages**. All new messages are indicated by a dot.

1. Press **Play**. Or, scroll  or  the list of messages. Press **Play** to hear the highlighted message.





## Outgoing messages

The outgoing message is the message a caller first hears when the answering machine picks up their call. There are 2 pre-recorded outgoing messages to choose from (see note right) or you can record your own. You can only record your outgoing message using the handset.

### Record your own outgoing message via the handset

1. Press **Menu**, scroll  to **Answer Machine** and press **Select**.
2. Scroll  to **Outgoing Message** and press **Select**.
3. **Record** is highlighted, press **Select**.
4. Scroll  or  to **Answer & Record** or **Answer Only** and press **Select**.
5. The display shows **Please speak after the tone**.
6. After the tone, speak your message clearly into the handset. Hold the handset in front of your mouth by approximately 30-40cm when recording your message (or memo). Press **Save** to end recording.
7. Your outgoing message is played back. If you want to delete it, press **Delete** during playback. If you press **Save** or wait for the message to play back, it will be saved.

### Check or delete your outgoing message

1. Press **Menu**, scroll  to **Answer Machine** and press **Select**.
2. Scroll  to **Outgoing Message** and press **Select**.
3. Scroll  to **Play** and press **Select**.
4. Scroll  or  to **Answer & Record** or **Answer Only** and press **Select**.

### Answer and Record

The pre-set Answer and Record outgoing message, that allows your caller to leave a message, is "Hello, your call cannot be taken at the moment, so please leave your message after the tone".

Your Answer and Record outgoing message can be up to 3 minutes long and will replace the pre-recorded message.

### Answer Only

The pre-set Answer Only outgoing message, where callers hear an announcement but cannot leave a message, is "Hello, your call cannot be taken at the moment and you cannot leave a message, so please call later".

When recording your Answer Only message, remember to advise your caller that they will not be able to leave a message.







Your Answer Only message can be up to 3 minutes long (maximum recording length) and will replace the pre-recorded message. However, you should try to keep your message short to allow time for recording memos, or incoming messages when using Answer and Record mode.

Deleting a personal outgoing message automatically reinstates the pre-recorded outgoing message.



You cannot delete a pre-recorded message.

5. Press  to Personal OGM and press **Select**.
6. The message is played. Press **OK** to stop playback or press **Delete** to delete a personal outgoing message.
7. Press **Back** to return to the previous menu level.



## Select outgoing message mode via the handset

1. Press **Menu**, scroll  to **Answer Machine** and press **Select**.
2. Scroll  to **Answer Settings** and press **Select**.
3. **Answer Mode** is highlighted, press **Select**.
4. Scroll  or  to **Answer & Record** or **Answer Only** and press **Select**.
5. If there is a personal outgoing message saved, press  or  to **Default OGM** or **Personal OGM** and press **Select**. Your selection is confirmed.  
If there is no personal outgoing message saved the default outgoing message will be selected.
6. Press **Back** to return to the previous menu level.

## Select outgoing message mode via the base

1. Press and hold . You hear “Please select outgoing message”.
2. Press  to hear “Answer and Record” or  to hear “Answer Only”.

## Record a memo

1. Press **Menu**, scroll  to **Answer Machine** and press **Select**.
2. Scroll  to **Record Memo** and press **Select**.
3. The display shows **Please speak after the tone**.
4. After you hear the tone, speak your memo then press **Save** to end recording.
5. Your memo is played back. If you want to delete it, press **Delete** during playback. If you press **Save** or wait for the message to play back, it will be saved.
6. Press **Back** to return to the previous menu level.

Choose which outgoing message you want played to callers.

Memos can only be recorded via the handset.







## Call screening

1. When your BT Synergy rings, wait for the answering machine to take the call. When the caller begins leaving a message, the display shows **Recording**. Press **Screen** to hear the caller.
2. To interrupt and speak to the caller directly, press **Talk**. Or, after the caller has hung up, and the display shows **You have a new message**, press **Play** to play new messages.
3. Press **Back** to return to the previous menu level.

## Message playback via the base



1. Press **Play**. New messages are played first.

During playback:

-  to delete the current message.
-  once to repeat the message.
-  twice to play the previous message.
-  to play the next message.
-  to pause and resume playback.
-  to stop playback
-  adjust the speaker volume during playback

At the end of playback press and hold  to delete all old messages.

## Message playback via the handset

1. Press **Menu** and scroll  to **Answer Machine**. Press **Select**.
2. **Play** is highlighted. Press **Select** to choose which messages you want to play or scroll  to **Play All** and press **Select** to play all messages.
3. Press **Talk** to switch between the earpiece and handset loudspeaker.

When the answering machine is on and takes a call, you can use the loudspeaker to listen to the caller leaving a message. You can then identify the caller and decide whether to take the call in person.

While screening, you can adjust the volume by pressing  or .

Each message is played back with the day and time of the call announced as well as the caller's number (if available) and name if stored in the phonebook.

When a memo is played back, the caller's name and number is displayed if available.



### Handset button shortcuts

During playback:

- 1** To pause
- 2<sup>nd</sup>** To resume
- 3<sup>rd</sup>** To repeat message
- 4<sup>th</sup>** To play previous message
- 5<sup>th</sup>** To delete current message
- 6<sup>th</sup>** To play next message



Answering Machine messages that are not deleted are automatically saved.

New / unplayed messages cannot be deleted.

During playback press **Options** then scroll  or  to: **Pause**, **Repeat Message**, **Skip Forward**, **Skip Backward**, **Delete**.

4. Press **Select** to choose the highlighted option. At the end of playback, press **Back** to return to the previous menu level.







## Delete all old messages

1. Press **Menu**, scroll  to **Answer Machine** and press **Select**.
2. Scroll  to **Delete Messages** and press **Select**.
3. Display shows **Delete all old messages?** Press **Yes** to confirm or **No** to cancel.
4. Press **Back** to return to the previous menu level.







## Remote access

You can operate your answering machine from any Touchtone™ phone by calling your BT Synergy 6500 and entering a 4 digit security code.

### Switch remote access PIN On or Off.

1. Press **Menu**, scroll  to **Answer Machine** and press **Select**.
2. Scroll  to **Answer Settings** and press **Select**.
3. Scroll  or  to **Remote Access** and press **Select**.
4. Scroll  or  to highlight **On** or **Off** and press **Select**.
5. Press **Back** to return to standby.

### Change the remote access PIN

1. Press **Menu**, scroll  to **Answer Machine** and press **Select**.
2. Scroll  to **Answer Settings** and press **Select**.
3. Scroll  or  to **Remote Access** and press **Select**.
4. Scroll  or  to highlight **SET remote PIN** and press **Select**.

### Memory full

If the memory is within 10 seconds of becoming full while a caller is leaving a message, they will hear, "Please complete your message within 10 seconds". If they are still talking when the memory becomes full the caller hears, "Thank you for calling", and the machine will hang up.

The outgoing message will set to **Answer Only**. You must delete messages before your BT Synergy 6500 can record new messages.

### IMPORTANT

You should change the security PIN from the original setting of 0000.

It is advisable to make a note of your new PIN code and keep it somewhere safe.

5. Enter the Old 4-digit PIN and press **Save**.  
(Default setting = 0000)
6. Enter the new 4-digit PIN and press **Save**.
7. Enter the new PIN again and press **Save**.
8. Press **Back** to return to standby.

## Switch your answering machine on remotely

If you forget to switch your answering machine on, you can do it remotely from another phone.

1. Dial your telephone number and let it ring. After 20 rings you will hear your outgoing message.
2. Press **\***, then enter your security code.  
(Default setting = 0000)
3. Press **0** and your answering machine will switch on ready to answer incoming calls.

## Play messages

1. Dial your phone number. When you hear your outgoing message, press **\***.
2. Enter your 4 digit PIN.
3. Use the keypad to operate your answering machine:
  - 1 To hear main menu
  - 2 To play messages
  - 3 To play new messages
  - 4 To skip back during messages
  - 5 To delete during messages
  - 6 To skip forward during messages
  - 7 To set to answer only (or answer and record) depending upon the Answer Mode status of the product at that time.
  - 8 To record a new outgoing message
  - 9 To set answer off
  - 0 To set answer on

### Time saver

When you ring in to access your messages remotely, if your answering machine is set to time saver and you have new messages it will answer after 2 rings, if you do not have any new messages, it will answer after 6 rings. This means you can hang up after 3 rings knowing you have no new messages, saving you time and the cost of the call.

You cannot use this feature if you have BT Answer 1571 or Call Minder active as the call will be intercepted before the 20 rings.

Your handset will automatically return to standby if no button is pressed for 8 seconds or more.

If you have any new messages they will be played after you have entered your security PIN code.

If you enter an incorrect PIN code you will hear 'Incorrect security code. Please enter your security code'. You can try entering the code again. If it is still incorrect you will hear the voice prompt and your BT Synergy will hang up.

If no button is pressed for 8 seconds or more your BT Synergy will hang up.

# Text messaging

Welcome to the BT text messaging service on your BT Synergy. Your BT Synergy can send and receive text messages from participating mobile networks and compatible landline telephones in the UK.

The fixed line text service is provided under BT's terms and conditions for telephone service. These can be found by visiting the BT.com website at: <http://www.bt.com/terms>

## Subscribe to the text messaging service

When you send your first text message from your BT Synergy you will automatically be registered for the service.

On receipt of your first text through the service, the system will send you a welcome text message back. You may also register by sending the word 'Register' to 00000 upon which you will receive a confirmation message.

## Cost of the fixed line service

There is no subscription charge (other than the subscription to Caller Display). Visit the BT.com website ([www.bt.com](http://www.bt.com)) to find out how much it costs to send a text message (depends upon your call package).

## Send a text message

1. Press **Menu**, **Text Messaging** is displayed, press **Select**.
2. **Write Message** is highlighted. Press **Select**.
3. Use the keypad to enter your message.
4. Press **Options**.

**Send** is highlighted Press **Select** to send the message.  
Enter the phone number or press **Search** to open the phonebook then scroll to the number you want and press **Select**. Now press **Send**.

### IMPORTANT

You must subscribe to your Network Provider's Caller Display service so that you can use text messaging and you must not withhold your telephone number.



A quarterly fee may be payable, please contact your network provider for more details.

Some other network provider lines may not be compatible with this text messaging service.

You may also send messages to landline phones that are NOT text compatible. Messages to non-compatible lines will be connected to voice text and delivered in spoken words to the telephone as a call. Please note that the conversion can translate common abbreviations and smileys etc, but to ensure maximum clarity of message delivery, abbreviations etc should be used sparingly.

### Writing tips

Press **Clear** to delete incorrect characters.







Use  or  to move the cursor through the text, if you want to insert/delete text.

### Upper & lower case

Press  to switch between upper case ABC, lower case abc letters and numbers.

Maximum number of characters in a text message is 160. The display shows a character countdown from 160 down to 0 (Unless message size is set to 612 characters).

Or scroll  or  to:

- Save** Press **Select** to save the message in the Drafts folder.
- Insert Symbol** Press **Select**. The symbol table is displayed.  
Press  or  to highlight the symbol you want then press **Insert**.
- Insert Emoticon** Press **Select**. The Emoticon table is displayed.  
Press  or  to highlight the Emoticon you want then press **Insert**.
- Insert Template** Press **Select**. The list of templates is displayed.  
Press  or  to highlight the Template you want then press **Insert**.

4. When sending a message, the display shows **Sending Message** then **Message Sent**.



## Standard text entry

With standard text entry you can enter a word by pressing each letter button a number of times to display the character you want on the screen. For example, to write the word "Hello", press **4<sup>OH</sup>** twice, **3<sup>OP</sup>** twice, **5<sup>PK</sup>** three times, **5<sup>PK</sup>** three times and **6<sup>MB</sup>** three times.

## Receiving and reading text messages

When you receive a new text message, the  icon is displayed along with **You have X new messages**.

### Read a new message

- The Inbox is opened and the list of messages displayed. If you press **Back** the message is stored in the Inbox for reading later.
- In the Inbox scroll  (to more recent messages) or  (to earlier list of messages) through the list of messages.
- Highlight the message you want to read and press **Read** or press **Back** to return to Text messaging menu.
- Press  to return to standby.

If the text is unsuccessful, the message **Unable to send** will be displayed.

In order to send and receive text messages you must not withhold your number. On most networks if you normally withhold your number the 1470 prefix presents your number for you.

### Symbols

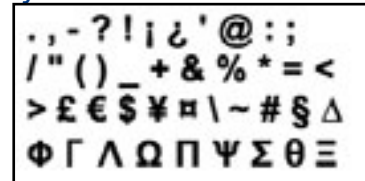

### Emoticons

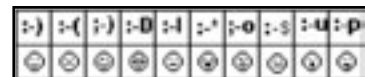

### Do you have two text phone bases connected to the same phone line?

If you have two text phone base stations plugged into one line, you are likely to experience problems receiving text messages. Normally, only one SMS enabled base unit (DECT or cordless) can be plugged into any line.

If you do want to use two base units and still receive written text you must delete receive service centre number from one of the base stations. To do this on your BT Synergy, see page 52. This will allow you to send text via either base station but texts will only be received on the product with the active receive centre number.

If you want to keep more than one text enabled phone connected, see the alternative method on page 60 for instructions.

### Total number of messages





Your BT Synergy can store up to a total of 50 short messages across all handset Outboxes, Drafts boxes and Inboxes.





## Read, forward, delete, view and save numbers of texts in the Inbox

When you see the new message alert, if you press **Back** the message is stored in your Inbox so you can read it later.

1. Press **Menu**, **Text Messages** is displayed. If you have new messages you will go straight to the Inbox, if not scroll  to Inbox and press **Select**.

2. Scroll  or  to the message you want and press **Read**. Scroll  or  through the message.

3. Press **Options** and scroll  or  to:

**Reply**

Press **Select**. Write your reply then press **Options** and select **Send**.



**Forward**

Press **Select**. The message is displayed. Press **Options**. Display highlights **Send**. Press **Select** and enter a number or search for the number then press **Send**.

**Message Details**

You can see who sent the message and then call them. Press **Select** the sender's number is displayed. Press **Dial** if you want to call the number.

**Use Number**

To call the sender, press **Select**. The display shows **Call**. Press **Select** to call the sender OR to save the number, scroll  to **Save** and press **Select**. Enter a name and press **OK**, edit the number if required then press **Save**. Scroll  or  to the ringtone and press **Select**. The number is saved in the phonebook.

**Delete**

Press **Select**. Press **Yes** to confirm or **No** to cancel.

### Memory full alert

If the text mailboxes are full when you attempt to write a new message the display shows **Memory Full Delete Messages** for 2 seconds. You must delete messages before you can write and send a new one.

### Templates

There are three pre-set templates:  
Please call  
I'll be there at  
What time will you be home?

You can edit the templates, up to a maximum of 32 characters.

### Receiving a call while writing a text

If you are writing a text and you receive a call the text will be lost.

### Sent texts are stored in the Outbox



Your BT Synergy's outbox is like a redial list. It holds a copies of up to 5 sent messages. When the Outbox is full, a new message replace the oldest.







### Saved messages are stored in the Drafts box

If you save a message to complete or send later it will be stored in the Drafts box. Only one message can be saved in each user's Drafts box.

Received messages are stored in the Inbox.







## Edit or send texts in the Drafts box

1. To open the Drafts box, press **Menu**, **Text Messaging** is displayed. Press **Select**.
2. Scroll  to **Drafts** and press **Select**.
3. Press **Edit** to edit your message content.
4. Press **Options** and scroll  or  to:

<b>Send</b>	Press <b>Select</b> to send the message. Enter the phone number or press <b>Search</b> to open the phonebook then scroll to the number you want and press <b>Select</b> . Press <b>Send</b> .
<b>Save</b>	Press <b>Select</b> to save the message in the Drafts folder.
<b>Insert Symbol</b>	Press <b>Select</b> . The symbol table is displayed. Press  or  to highlight the symbol you want then press <b>Insert</b> .
<b>Insert Emoticon</b>	Press <b>Select</b> . The Emoticon table is displayed. Press  or  to highlight the Emoticon you want then press <b>Insert</b> .
<b>Insert Template</b>	Press <b>Select</b> . The templates list is displayed. Press  or  to highlight the Template you want then press <b>Insert</b> .

5. When sending a message, the display shows **Sending Message** then **Message Sent**.

## Forward or delete texts in the Outbox



1. To open the Outbox box, press **Menu**, **Text Messaging** is displayed.  
Press **Select**. Scroll  to **Outbox** and press **Select**.
2. Scroll  or  to the message you want and press **Read**.  
Scroll  or  through the message.
3. Press **Options** and scroll  or  to:

**Forward** Press **Select**. The message is displayed.  
Press **Options**. Display highlights  
**Send**.  
Press **Select** and enter the number  
or press **Search** to search the  
phonebook. When the number  
is entered, press **Send**.

**Delete** Press **Select** then press **Yes** to confirm  
or **No** to cancel.

4. Press  to return to standby.

## Edit templates

1. Press **Menu**, **Text Messaging** is displayed. Press **Select**  
scroll  to **Templates** and press **Select**.
2. Scroll  or  to the template you want and press **Options**.

**Edit** Press **Select**. Press **Clear** to  
delete characters. Enter your template  
text and press **Save**.

**Delete** Press **Select**. Press **Yes** to confirm  
or **No** to cancel.

3. Press  to return to standby.

### Edit templates



There are three pre-set templates:  
Please call  
I'll be there at  
What time will you be home?

You can change the templates to your  
preferred message, up to a maximum  
of 32 characters.

If you delete a template without  
replacing the text it is marked  
as **EMPTY**.

All templates are restored if you reset  
your BT Synergy 6500 to its default  
settings, see page 28.

## Deleting texts

1. Press **Menu**, **Text Messaging** is displayed. Press **Select**, scroll  to **Delete Messages** and press **Select**.
2. Scroll  or  to **Inbox**, **Drafts**, **Outbox** or **All Messages** and press **Select**.
3. Press **Yes** to confirm or **No** to cancel.
4. Press **Back** to return to standby.







## Service Centre numbers

To send and receive text messages you need the telephone number of your Network's text Centre. If you accidentally delete the Outgoing or Incoming Service Centre numbers you will need to re-enter them in order for your text Service to work. You can enter up to 4 Service Centre numbers – two incoming and two outgoing.

The Send Centre number is: 1470P1709400.

The Receive Centre is: 080058752.

## Add or change Service Centre numbers

1. Press **Menu**, **Text Messaging** is displayed. Press **Select**, scroll  or  to **Text Settings** and press **Select**.
2. **Service Centres** is highlighted press **Select**.
3. Scroll  or  to **Receive Centres** or **Send Centre** and press **Select**.
4. Scroll  or  to **Centre 1** or **Centre 2** and press **Select**.
5. Enter the number for the centre and press **Save**.
6. Press **Back** to return to the previous menu level.





Selecting **All messages** will delete all messages stored in your **Inbox**, **Outbox** and **Drafts** box.

If you have more than one 'Server Centre' stored on your BT Synergy you will need to select which one you want to use for sending (see next section).





### WARNING

The Service Centre number is associated with the "Mailbox Number" setting on your BT Synergy 6500. The "Mailbox Number" should be set to 9 under normal circumstances. Further information is available from the Helpdesk for non-BT telephone network users.





## Set send centre

1. Press **Menu**, **Text Messaging** is displayed. Press **Select**.  
Scroll  or  to **Text Settings** and press **Select**.
2. **Service Centres** is highlighted press **Select**.
3. Press **Select** again to choose **Set Send Centre**.
4. Scroll  or  to **Receive Centre 1** or **Receive Centre 2** or **Send Centre 1** or **Send Centre 2** and press **Select**.
5. Press **Back** to return to the previous menu level.

## Message alert tone

1. Press **Menu**, **Text Messaging** is displayed. Press **Select**.  
Scroll  to **Text Settings** and press **Select**.
2. Scroll  to **Message Alert** and press **Select**.
3. Scroll  or  to **On** or **Off** and press **Select**.
4. Press **Back** to return to the previous menu level.

## Set message size

1. Press **Menu**, **Text Messaging** is displayed. Press **Select**.  
Scroll  to **Text Settings** and press **Select**.
2. Scroll  to **Message Size** and press **Select**.
3. Scroll  or  to highlight **160** or **612** characters, then press **Select**.
4. Press **Back** to return to the previous menu level.

When you receive a text message, the message alert tone will sound. These beeps can be switched on or off.

A standard text message is 160 characters long. You can set a message to be up to 612 characters and the message will be sent as up to 4 linked messages each up to 160 characters long.

# Using additional handsets

You can use up to five BT Synergy additional handsets with your BT Synergy 6500 base to extend your phone system without needing to install extension sockets for each new phone.

Your BT Synergy 6500 handset can also be registered to up to 3 other bases. You can then select the base you would prefer to use.

If you have purchased a BT Synergy 6500 multiple pack any additional handsets come pre-registered to the base.

If you have purchased an additional handset separately you must register it to your BT Synergy 6500 base before it can be used.

## Registering an additional handset



At the base:



1. Press and hold  for 3 seconds until the base Power / In use light starts flashing. You have up to 60 seconds to register the handset.

At the handset:

1. If the handset is new and the display shows **Please Register**. Press **Menu**. The display shows **Registration**. Press **Select**.

Or

If the handset has already been registered to another base the standby display is shown. Press **Menu**, scroll  or  to **Registration** and press **Select**.

2. **Register Handset** is highlighted. Press **Select**.
3. Bases are displayed. If necessary, scroll  or  to a new base you wish to register your BT Synergy 6500 handset to and press **Select**.
4. Enter the system PIN and press **OK**.
5. The display shows **Searching Base X** (where X is the chosen base number) then **Handset Registered**.

The handset is automatically assigned the next available handset number.





Default PIN code = 0000

If registration is not successful first time, please repeat the process again in case the base registration period ran out of time.





If there are already 5 handsets registered to the base, the registration will fail. You must de-register another handset before you can register the new one.

## Select a base

If your BT Synergy handset is registered to more than one base, you can select which base to use.

1. Press **Menu**, scroll  or  to **Registration** and press **Select**.
2. Scroll  to **Select Base** and press **Select**.
3. All base numbers are displayed. (In use) is added to bases where the handset was previously registered to. Scroll  or  to the base you want and press **Select**.
4. Display shows **Searching Base...** then the standby display for that base.

## De-register a handset

1. Press **Menu**, scroll  or  to **Registration** and press **Select**.
2. Scroll  to **De-register** and press **Select**.
3. Enter the system PIN and press **OK**.
4. Scroll  or  to the handset you want to de-register and press **Select**.
5. Press **Yes** to confirm or **No** to cancel. The display confirms de-registration.
6. Press **Back** to return to the previous menu level.

## Internal calls

### Call another handset

If you have more than one handset registered to the base, you can make internal calls between two handsets.

1. Press  then the number (1-5) of the handset you want to call.
2. Press **OK** to dial.

Use one handset to de-register another. You cannot de-register the handset you are using.

Default PIN code = 0000

### Handset external display

When an internal call is received, the display shows **Internal Call Handset X** (where X is the calling handset) and the handset number.

If all handsets are on an internal call, then any incoming external call will be indicated by a tone in the earpiece and the caller's details will be shown on the display (if you have subscribed to a Caller Display Service, see page 34).

## Transfer a call

You can transfer an external call to another handset registered to the base.

During your call:

1. Press **Intercom** then the handset number (1-5) you want.
2. Press **OK** to dial or press **End** to cancel the calls request and return to the caller.
3. When the other handset answers you can announce the caller.
4. Press **Join** to complete the transfer or **Intercom** to switch back and forth between both callers.

## 3-Way conference call

You can hold a 3-way conference call between 2 internal callers and 1 external caller.

During a call to an external caller:

1. Press **Intercom** then the handset number (1-5) you want.
2. Press **OK** to dial.
3. When the other handset answers you can announce the caller.
4. Press **Join** to begin the conference call. Display shows **Conference Call**.
5. Press **Join** to hang up.

If the other handset does not answer, press **End** to return to your original caller.



# Help

## Phone does not work

- Have you installed the batteries correctly?
- Check that the mains power is correctly connected.

## No dial tone

- Is the telephone cord of the base plugged into the phone socket?
- Check that the mains power is correctly connected to the base and to the handset charger(s).
- Only use the telephone cord supplied with the phone.

## Cannot dial out or receive calls

- Check that the mains power is correctly connected.
- The batteries may need recharging.
- Has there been a power cut? If so, place the handset back on the base for 10 seconds and try again. If it still does not work disconnect the batteries and mains power for 10 minutes, then reconnect and try again.

## You have a dial tone, but the phone will not dial out

- You may need to change the dial mode from tone to pulse, see page 26.
- If you are connected to a switchboard, check whether you need to dial an access code.

## Handset does not ring

- The ringer volume may be switched off, see page 22.
- Check that the mains power is correctly connected.
- Make sure the handset is registered to the base, see page 54.

## No display

- The batteries may be flat, dead or incorrectly inserted. Recharge or replace the batteries.

### icon flashes

- Is the handset registered correctly to the base, see page 54.
- Check that the mains power is correctly connected.
- Check that the handset is within range of the base.
- The batteries are low, place the handset on the base/charger to recharge.

### icon not scrolling

- Try cleaning the charging contacts.
- Check that the mains power is correctly connected.

### You hear the busy tone when you press .

- Make sure the handset is in range of the base.
- Another handset registered to your BT Synergy 6500 base may be on the line.

### Answering machine does not record any messages

- The memory may be full. Play and delete old messages, see page 44.

### Answering machine messages have the wrong date and time

- Have you set the date and time? See page 29.

### Cannot access your messages from another phone

- Have you changed the remote access security PIN code? See page 45. Always keep a note of the new PIN code in a safe place.

### No Caller Display number/name displayed

- Have you subscribed to a Caller Display service from your network provider, see page 34.
- The caller may have withheld their number.
- An exact name/number match was not found in your directory. Check that you have stored the full STD dialling code.

## Cannot register a handset to a base

- You can register a total of 5 handsets to your BT Synergy 6500 base and you can register your BT Synergy 6500 handset to up to 4 bases. Check that you have not exceeded the limits.
- Check that you have entered the correct PIN number (default PIN 0000).
- Check that you are at least one metre away from other electrical equipment to avoid interference when registering.

## Base unit does not ring, but the lights are on

- Have you connected the telephone line correctly?
- Is the base ringer set to off?
- You may have a faulty line or socket. Try using another socket or line. Call BT on 151 if you still experience problems.

## Buzzing noise on my phone or on other electrical equipment nearby

- Sometimes your BT Synergy 6500 can interfere with other electrical equipment if it is placed too close. It is recommended that you place your BT Synergy 6500 at least one metre away from electrical appliances or metal obstructions to avoid any risk of interference.

## Customer Helpline

If you are still experiencing difficulties please call the BT Synergy Helpline on 0800 145 6789\* or email [bt.helpdesk@sgweurope.com](mailto:bt.helpdesk@sgweurope.com).

## Possible problems with text messaging

You must subscribe to your network provider's Caller Display service for text messaging to work and you must not withhold your number. Your network provider may charge you for these services. Please note some other network provider lines may not be compatible with this text messaging service.

## Text messages cannot be sent and screen displays Message Sending Failed

- The base station power supply or telephone line cord might not be properly connected. Check that the base station power supply is plugged into the mains socket and switched on and that the telephone is plugged into the telephone wall socket.
- There might be a fault on the line. Check your telephone line is working properly.
- You might have deleted the server number in error. See page 52 for instructions on how to enter the number.

## Cannot send text

- Check service centre number is correct including 1470P prefix (this is for BT lines. If you have another network provider please check the prefix number with them). In order to send and receive text messages you must not withhold your number. If you normally withhold your number the 1470 prefix presents your number for you.

## Cannot receive text

- You will not be able to receive text messages until you have first sent a message. The first message sent registers you with the text service.
- More than one text messaging product is plugged into the line. Remove other products.
- Check service centre number is correct.
- Ensure you have subscribed to a Caller Display service and that it is active. You can check this by noting if your phone displays your caller's number when you receive an incoming call.
- If you are using personal user areas please ensure you have given people your user area number and that they are entering it to the end of your telephone number when sending you a text message.

## I want to use more than one text (SMS) enabled product on my telephone line

It is possible to connect more than one SMS product to the same telephone line and for both of them to send and receive Text messages, but you must amend the final digit of both the Send and Receive Service Centre telephone numbers first.

All BT text capable telephones are provided with the same send and receive telephone numbers, but with two or more text capable telephones connected to the same telephone line, delivery of text messages becomes unreliable causing the text to be delivered as a normal telephone call which when answered will be an electronic Text to Speech message.

To overcome this problem you must keep one of the products as it is with the default Send & Receive ending in a '9', but for the second and subsequent products you must change the final digit of the Service Centre numbers (from the default '9') to any unique number between 1 and 8 i.e for a second product change last digit from a '9' to a '1' by changing the Send number from 1470P17094009 to 1470P17094001 and the Receive number from 0800587529 to 0800587521. For the Send number, go into *Text - Settings- Send centre 1-* and amend the last digit and then press *Save....* (For Rcv. Centre, go into *Text - Settings - Rcv. Centre 1* and amend the last digit and then press *Save*).

Once changed, for the products that you have assigned new send and receive numbers, you need to send a new registration text to the Fixed Line Text Service platform to register the new identity (i.e. send a text to 00000 from the product that you changed the Send & Receive numbers). You can then send and receive text messages from more than one product.

## Text has previously been sent and received but you are now only receiving voice spoken text messages, from number 0845 6021111

- This may be due to your line being de-registered at the text service centre. All you need to do is text RESET and send it to 00000. You will receive a confirmation message back.

This assumes that your Caller Display service is active and working on your line. Messages sent to 00000 are free.

## Further help and advice for text queries on BT lines:

- BT Residential customers – call 151, choose option 2, when prompted by the Fault Management Service select option 2, enter your phone number on the handset and wait to speak to a customer adviser.
- BT Business Customers – call 152, choose option 2, when prompted by the Fault Management Service select option 2, enter your phone number on the handset and wait to speak to a customer adviser.
- For other telephone service providers please contact their customer services.

## General sales enquiries

- BT Residential lines – call 150. BT Business lines – call 152.
- For non BT line customers, call 0800 800 150 (residential) or 0800 800 152 (business).
- Additional handsets are available from the Helpdesk on 0800 145 6789\*.

## Billing enquiries

- Refer to the telephone number shown on your telephone bill.

## Other functions and services available from the text messaging service

By sending the following commands to the BT text self administration facility you can control functions and capabilities in your text phone and the way messages are handled.

1. Press **Menu**, **Text Messaging** is displayed, press **Select**.
2. **Write Message** is highlighted. Press **Select**.
3. Use the keypad to type in the following commands (depending upon what you want to do):
  - Opt out from receiving voice text messages.
  - Turns off the opt out option.
  - Turns on permanent voice text message delivery to your phone.

All incoming text is delivered as voice text.

Turns off permanent voice text message delivery.

4. Press **Options**. Display highlights **Send**.
5. Enter the number 00000 then press **Send**.

### **If you are sending a message from a fixed line phone to another fixed line phone**

Forces a message you send to be delivered as a voice text even though the recipient may have a text enabled phone and usually receives written text. This command is inserted at the start of the message and applies only to that message, e.g. 'Hello I will be home late'.

### **You keep hearing an error beep**

- You have pressed the wrong button in a sequence. Check the prompts in the display or refer to instructions in this user guide.

# General information

## IMPORTANT

This equipment is not designed for making emergency telephone call when the power fails. Alternative arrangements should be made for access to emergency services.

This product is intended for connection to analogue public switched telephone networks and private switchboards in the United Kingdom.

## Safety information

- Only use the power supply suitable for the BT Synergy 6500 range. Using an unauthorised power supply will invalidate your guarantee and may damage the telephone. The item code for the base mains power supply is 040497. The item code for the small mains power supply for the charger is 032765.
- Use only the approved rechargeable batteries supplied. Spare rechargeable batteries are available from the BT Synergy Helpline on 0800 145 6789\*. There is a risk of explosion if the batteries are replaced by an incorrect type.
- Do not open the handset (except to replace the handset batteries) or the base. This could expose you to high voltages or other risks. Contact the Helpline on 0800 145 6789\* for all repairs.
- Radio signal transmitted between the handset and base may cause interference to hearing aids.
- It is recommended that advice from a qualified expert be sought before using this product in the vicinity of emergency/intensive care medical equipment.
- It is recommended that if you have a pacemaker fitted you check with a medical expert before using this product.
- Your product may interfere with other electrical equipment, e.g. TV and radio sets, clock/alarms and computers if placed too close. It is recommended that you place your product at least one metre away from such appliances to minimise any risk of interference.
- Never dispose of batteries in a fire. There is a serious risk of explosion and/or the release of highly toxic chemicals. Dispose of batteries according to the instructions.

## Cleaning

- Clean the handset and base (or charger) with a damp (not wet) cloth, or an anti-static wipe.

Never use household polish as this will damage the product. Never use a dry cloth as this may cause a static shock.

## Environmental

- Do not expose to direct sunlight.
- The handset may become warm when the batteries are being charged or during prolonged periods of use. This is normal. However, we recommend that to avoid damage you do not place the product on antique/veneered wood.
- Do not stand your product on carpets or other surfaces which generate fibres, or place it in locations preventing the free flow of air over its surfaces.
- Do not submerge any part of your product in water and do not use it in damp or humid conditions, such as bathrooms.
- Do not expose your product to fire, explosive or other hazardous conditions.
- There is a slight chance your phone could be damaged by an electrical storm. We recommend that you unplug the power and telephone line cord during an electrical storm.

## Product disposal instructions

The symbol shown here and on the product means that the product is classed as Electrical or Electronic Equipment and should not be disposed with other household or commercial waste at the end of its working life.



The Waste of Electrical and Electronic Equipment (WEEE) Directive (2002/96/EC) has been put in place to recycle products using best available recovery and recycling techniques to minimize the impact on the environment, treat any hazardous substances and avoid the increasing landfill.

### Product disposal instructions for residential users

When you have no further use for it, please remove any batteries and dispose of them and the product as per your local authority's recycling processes. For more information please contact your local authority or the retailer where the product was purchased.

### Product disposal instructions for business users

Business users should contact their suppliers and check the terms and conditions of the purchase contract and ensure that this product is not mixed with other commercial waste for disposal.



## Guarantee

Your BT Synergy 6500 is guaranteed for a period of 12 months from the date of purchase.

Subject to the terms listed below, the guarantee will provide for the repair of, or at BT's or its agent's discretion, the option to replace the BT Synergy 6500 or any component thereof, (other than batteries), which is identified as faulty or below standard, or as a result of inferior workmanship or materials. Products over 28 days old from the date of purchase may be replaced with a refurbished or repaired product.

### The conditions of this guarantee are:

- The guarantee shall only apply to defects that occur within the 12 month guarantee period.
- Proof of purchase is provided.
- The equipment is returned to BT or its agent as instructed.
- This guarantee does not cover any faults or defects caused by accidents, misuse, fair wear and tear, neglect, tampering with the equipment, or any attempt at adjustment or repair other than through approved agents.
- This guarantee does not affect your statutory rights.

### Within the 12 month guarantee period:

If you experience difficulty using the product, prior to returning your product, please read the Help section beginning on page 57 or contact the BT Helpdesk for assistance on 0800 145 6789\* or email [bt.helpdesk@sgweurope.com](mailto:bt.helpdesk@sgweurope.com). Additional answers to Frequently Asked Questions are available from [www.bt.com/producthelp](http://www.bt.com/producthelp)

In the unlikely event of a defect occurring, the helpdesk will issue a Fault Reference Authorisation (FRA) number and instructions for replacement or repair. Please note you will need the FRA number before returning the product. This does not affect your statutory rights.

### Outside of the 12 month guarantee period:

If your product needs repair after the guarantee period has ended, the repair must meet the approval requirements for connection to the telephone network.

If you require technical assistance outside of the 12 month guarantee period, please call BT's approval technical support agent Helpdesk Solutions on 0870 240 5029.

For guarantee purposes proof of purchase is required so please keep your receipt.

## Returning your phone

If the Helpline is unable to remedy your problem they will issue a Fault Reference Authorisation number and ask you to return the product to your original place of purchase. Where possible, pack the product in its original packaging. Please remember to include all parts, including the line cords, power supply units and the original batteries.

## Technical information

### How many telephones can I have?

All items of telephone equipment have a Ringer Equivalence Number (REN), which is used to calculate the number of items which may be connected to any one telephone line. Your BT Synergy 6500 has a REN of 1. A total REN of 4 is allowed. If the total REN of 4 is exceeded, the telephones may not ring. With different telephone types there is no guarantee of ringing, even when the REN is less than 4.

Any additional handsets and chargers that you register have a REN of 0.

## R&TTE

This product is intended for use within the UK for connection to the public telephone network and compatible switchboards.

This equipment complies with the essential requirements for the Radio Equipment and Telecommunications Terminal Equipment Directive 1999/5/EC.

### Declaration of Conformance

Hereby, Suncorp Technologies declares that this BT Synergy 6500 is in compliance with the essential requirements and other relevant provisions of Directive 1999/5/EC.

The Declaration of Conformance for the BT Synergy 6500 is published on the website:  
<http://www.bt.com/producthelp>

### Connecting to a switchboard

This product is intended for use within the UK for connection to the public telephone network and compatible switchboards, which support tone and pulse dialling and timed break recall. If in doubt please consult your service provider.

## Inserting a pause

With some switchboards, after dialling the access code you may have to wait for a moment while the switchboard picks up an outside line so you will need to enter a pause in the dialing sequence.

Press and hold  to insert a pause (P) before entering the telephone number.

You may also need to enter a pause when storing international numbers or charge card numbers.

## Recall

You may need to use the recall function if you are connected to a switchboard/PBX (Private Branch Exchange), contact your PBX supplier for further information. The recall function is set to timed break recall and is also used for BT Calling Feature.

## User Guide formats

This document is also available in other formats, such as Large print, Braille and Audio CD. If you would like a copy, please call 0800 145 6789\*.



Working together, supporting energy saving products

BT & British Gas have joined forces to help our customers find new ways to save energy around the home, so we can all do our bit for the environment & save money too!

BT is a **sustainability leader**

{ To find out how we're  
making our products  
greener visit

[bt.com/betterworld/products](http://bt.com/betterworld/products) 

#### Offices worldwide

The services described in this publication are subject to availability and may be modified from time to time. Services and equipment are provided subject to British Telecommunications plc's respective standard conditions of contract. Nothing in this publication forms any part of any contract.

© British Telecommunications plc 2010.  
Registered Office: 81 Newgate Street, London EC1A 7AJ.  
Registered in England No. 1800000.  
Printed in China.

Designed and produced by The Art & Design Partnership Ltd.

BT Synergy 6500 (06/10) Issue 1

